

## SECTION: CONTROL, RELAY & PROTECTION PANELS

### 1. TYPE OF PANELS

#### 1.1 Simplex Panel

Simplex panel shall consist of a vertical front panel with equipment mounted thereon and having wiring access from rear for control panels & front for relay/protection/**Interface** panels. In case of panel having width more than 800mm, double leaf-doors shall be provided. Doors shall have handles with built-in locking facility.

#### 1.2 Duplex Panel

Duplex panel shall be walk-in tunnel type comprising two vertical front and rear panel sections connected back-on-back by formed sheet steel roof tie members and a central corridor in between. The corridor shall facilitate access to internal wiring and external cable connections. In case of number of duplex panels located in a row side by side, the central corridor shall be aligned to form a continuous passage. Both ends of the corridor shall be provided with double leaf doors with lift off hinges. Doors shall have handles with built-in locking facility. Separate cable entries shall be provided for the front and rear panels. However, inter-connections between front and back panels shall be by means of inter panel wiring at the top of the panel.

### 2. CONSTRUCTIONAL FEATURES

- 2.1. Control and Relay Board shall be **simplex type unless otherwise indicated in section-project / bill of quantity as duplex type**. It is the responsibility of the Contractor to ensure that the equipment specified and such unspecified complementary equipment required for completeness of the protective/control schemes be properly accommodated in the panels without congestion and if necessary, either more number of panels or panels with larger dimensions **shall be provided (as per panel layout requirement)**. No price increase at a later date on this account shall be allowed. However, the width of panels that are being offered to be placed in existing switchyard control rooms, should be in conformity with the space availability in the control room.
- 2.2. Panels shall be completely metal enclosed and shall be dust, moisture and vermin proof. The enclosure shall provide a degree of protection not less than IP-31 in accordance with IS: 2147.
- 2.3. Panels shall be free standing, floor mounting type and shall comprise structural frames completely enclosed with specially selected smooth finished, cold rolled sheet steel of thickness not less than 3 mm for weight bearing members of the panels such as base frame, front sheet and door frames, and 2.0mm for sides, door, top and bottom portions. There shall be sufficient reinforcement to provide level transportation and installation.
- 2.4. All doors, removable covers of panels shall be gasketed all around with synthetic gaskets Neoprene/EPDM generally conforming with provision of

IS 11149. However, XLPE gaskets can also be used for fixing protective glass doors. Ventilating louvers, if provided shall have screens and filters. The screens shall be made of either brass or GI wire mesh.

- 2.5. Design, materials selection and workmanship shall be such as to result in neat appearance, inside and outside with no welds, rivets or bolt head apparent from outside, with all exterior surfaces true and smooth.
- 2.6. Panels shall have base frame with smooth bearing surface, which shall be fixed on the embedded foundation channels/insert plates. Anti vibration strips made of shock absorbing materials that shall be supplied by the contractor, which shall be placed between panel & base frame.
- 2.7. Cable entries to the panels shall be from the bottom. Cable gland plate fitted on the bottom of the panel shall be connected to earthing of the panel/station through a flexible braided copper conductor rigidly.
- 2.8. Relay/protection panels of modern modular construction **meeting the functional requirement** would also be acceptable.

### **3. MOUNTING**

- 3.1. All equipment on and in panels shall be mounted and completely wired to the terminal blocks ready for external connections. The equipment on front of panel shall be mounted flush.
- 3.2. Equipment shall be mounted such that removal and replacement can be accomplished individually without interruption of service to adjacent devices and are readily accessible without use of special tools. Terminal marking on the equipment shall be clearly visible.
- 3.3. The Contractor shall carry out cut out, mounting and wiring of the free issue items supplied by others which are to be mounted in his panel in accordance with the corresponding equipment manufacturer's drawings. Cut outs if any, provided for future mounting of equipment shall be properly blanked off with blanking plate.
- 3.4. The centre lines of switches, push buttons and indicating lamps shall be **preferably** not less than 750mm from the bottom of the panel. The centre lines of relays, meters and recorders shall be **preferably** not less than 450mm from the bottom of the panel.
- 3.5. The centre lines of switches, push buttons and indicating lamps shall be matched to give a neat and uniform appearance. Like wise the top lines of all meters, relays and recorders etc. shall be matched.
- 3.6. No equipment shall be mounted on the doors.
- 3.7. At existing station, panels shall be matched with other panels in the control room in respect of dimensions, colour, appearance and arrangement of equipment (centre lines of switches, push buttons and other equipment) on the front of the panel.

### **4. PANEL INTERNAL WIRING**

- 4.1. Panels shall be supplied complete with interconnecting wiring provided between all electrical devices mounted and wired in the panels and between the devices and terminal blocks for the devices to be connected to equipment outside the panels. When panels are arranged to be located adjacent to each other all inter panel wiring and connections between the panels shall be carried out internally.
- 4.2. All wiring shall be carried out with 650V grade, single core, stranded copper conductor wires with PVC insulation. The minimum size of the multi-stranded copper conductor used for internal wiring shall be as follows:
- All circuits except current transformer circuits and voltage **transformer** circuits meant for energy metering - one 1.5mm sq. per lead.
  - All current transformer circuits - one 2.5 sq.mm per lead.
  - Voltage transformer circuit (for energy meters): Two 2.5 mm sq. per lead.
- 4.3. All internal wiring including FO patch cords shall be securely supported, neatly arranged, readily accessible and connected to equipment terminals and terminal blocks. Wiring gutters & troughs shall be used for this purpose.
- 4.4. Void**
- 4.5. Wire termination shall be made with solderless crimping type and tinned copper lugs, which firmly grip the conductor. Insulated sleeves shall be provided at all the wire terminations. Core identification plastic ferrules marked to correspond with panel wiring diagram shall be fitted at both ends of each wire. Ferrules shall fit tightly on the wire and shall not fall off when the wire is disconnected from terminal blocks. All wires directly connected to trip circuit breaker or device shall be distinguished by the addition of red coloured unlettered ferrule.
- 4.6. Longitudinal troughs extending throughout the full length of the panel shall be preferred for inter panel wiring. Inter-connections to adjacent panel shall be brought out to a separate set of terminal blocks located near the slots of holes meant for taking the inter-connecting wires. **Wiring termination at interface panel end shall be through prefabricated plug-in type connectors.**
- 4.7. Contractor shall be solely responsible for the completeness and correctness of the internal wiring and for the proper functioning of the connected equipments.

## **5. TERMINAL BLOCKS**

- 5.1. All internal wiring to be connected to external equipment shall terminate on terminal blocks. Terminal blocks shall be 650 V grade and have 10 Amps. Continuous rating, moulded piece, complete with insulated barriers, stud type terminals, washers, nuts and lock nuts. Markings on the terminal blocks shall correspond to wire number and terminal numbers on the wiring diagrams. All terminal blocks shall have shrouding with transparent

unbreakable material.

- 5.2. Disconnecting type terminal blocks for current transformer and voltage transformer secondary leads shall be provided. Also current transformer secondary leads shall be provided with short circuiting and earthing facilities.
- 5.3. At least 20% spare terminals shall be provided on each panel and these spare terminals shall be uniformly distributed on all terminal blocks.
- 5.4. Unless otherwise specified, terminal blocks shall be suitable for connecting the following conductors of external cable on each side
  - All CT & PT circuits: minimum of two no. of 2.5mm Sq. copper.
  - AC/DC Power Supply Circuits: **two** no. of **16mm** Sq. Aluminium.
  - All other circuits: minimum of one no. of 2.5mm Sq. Copper.
- 5.5. There shall be an **approximate clearance** of 250mm between the first row of terminal blocks and the associated cable gland plate or panel side wall. **Similarly** the clearance between two rows of terminal blocks edges shall be of 150mm **approximate**.
- 5.6. Arrangement of the terminal block assemblies and the wiring channel within the enclosure shall be such that a row of terminal blocks is run in parallel and close proximity along each side of the wiring-duct to provide for convenient attachment of internal panel wiring. The side of the terminal block opposite the wiring duct shall be reserved for the external cable connections. All adjacent terminal blocks shall also share this field wiring corridor. All wiring shall be provided with adequate support inside the panels to hold them firmly and to enable free and flexible termination without causing strain on terminals.
- 5.7. The number and sizes of the Owner's multi core incoming external cables will be furnished to the Contractor after placement of the order. All necessary cable terminating accessories such as gland plates, supporting clamps & brackets, wiring troughs and gutters etc. (except glands & lugs) for external cables shall be included in the scope of supply. **Terminal blocks provided on Interface panel used for external wiring from switchyard shall be provided with necessary surge protection device to safeguard IEDs from transient voltage surges, spikes.**

## 6. PAINTING

The painting shall be carried out as detailed in Section–GTR.

## 7. MIMIC DIAGRAM (FOR CONTROL PANELS)

- 7.1. Coloured mimic diagram and symbols showing the exact representation of the system shall be provided in the front of control panels.
- 7.2. Mimic diagram shall be made preferably of anodised aluminium or plastic of approved fast colour material, which shall be screwed on to the panel and can be easily cleaned. The mimic bus shall be 2mm thick. The width of the mimic bus shall be 10mm for bus bars and 7mm for other

connections. Painted overlaid mimic is also acceptable.

- 7.3. Mimic bus colour will be decided during detailed Engineering by the **EMPLOYER**.
- 7.4. When semaphore indicators are used for equipment position, they shall be so mounted in the mimic that the equipment in close position shall complete the continuity of mimic.
- 7.5. Indicating lamp, one for each phase, for each bus shall be provided on the mimic to indicate bus charged condition

## **8. NAME PLATES AND MARKINGS**

- 8.1. All equipment mounted on front and rear side as well as equipment mounted inside the panels shall be provided with individual name plates with equipment designation engraved. Also on the top of each panel on front as well as rear side, large and bold nameplates shall be provided for circuit/feeder designation.
- 8.2. All front mounted equipment shall also be provided at the rear with individual name plates engraved with tag numbers corresponding to the one shown in the panel internal wiring to facilitate easy tracing of the wiring.
- 8.3. Each instrument and meter shall be prominently marked with the quantity measured e.g. kV, A, MW, etc. All relays and other devices shall be clearly marked with manufacturer's name, manufacturer's type and electrical rating data.
- 8.4. Name Plates shall be made of non-rusting metal or 3 ply lamicaid. Name plates shall be black with white engraving lettering.
- 8.5. Each switch shall bear clear inscription identifying its function e.g. 'BREAKER' '52A', "SYNCHRONISING" etc. Similar inscription shall also be provided on each device whose function is not other-wise identified. If any switch device does not bear this inscription separate name plate giving its function shall be provided for it. Switch shall also have clear inscription for each position indication e.g. "Trip- Neutral-Close", "ON-OFF", "R-Y-B-OFF" etc
- 8.6. All the panels shall be provided with name plate mounted inside the panel bearing LOA No & Date, Name of the Substation & feeder and reference drawing number.

## **9. MISCELLANEOUS ACCESSORIES**

- 9.1. **Plug Point:** 240V, Single phase 50Hz, AC socket with switch suitable to accept 5 Amps and 15 Amps pin round standard Indian plug, shall be provided in the interior of each cubicle with ON-OFF switch.
- 9.2. **Interior Lighting:** Each panel shall be provided with a **LED type lighting fixture (Min 7 Watt)** rated for 240 Volts, single phase, 50 Hz supply for the interior illumination of the panel controlled by the respective panel door switch. Adequate lighting shall also be provided for the corridor in Duplex panels.
- 9.3. **Switches and Fuses:** Each panel shall be provided with necessary

arrangements for receiving, distributing and isolating of DC and AC supplies for various control, signaling, lighting and space heater circuits. The incoming and sub-circuits shall be separately provided with Fuses. Selection of the main and sub-circuit Fuses rating shall be such as to ensure selective clearance of sub-circuit faults. Voltage transformer circuits for relaying and metering shall be protected by fuses. All fuses shall be HRC cartridge type conforming to IS: 13703 mounted on plug-in type fuse bases. The short time fuse rating of Fuses shall be not less than 9 KA. Fuse carrier base shall have imprints of the fuse 'rating' and 'voltage'.

- 9.4. **Space Heater:** Each panel shall be provided with a thermostatically **controlled** space heater rated for 240V, single phase, 50 Hz AC supply for the internal heating of the panel to prevent condensation of moisture. The fittings shall be complete with switch unit.

## 10. **EARTHING**

- 10.1. All panels shall be equipped with an earth bus securely fixed. Location of earth bus shall ensure no radiation interference from earth systems under various switching conditions of isolators and breakers. The material and the sizes of the bus bar shall be at least 25 X 6 sq.mm copper with threaded holes at a gap of 50 mm with provision of bolts and nuts for connection with cable armours and mounted equipment etc for effective earthing. When several panels are mounted adjoining each other, the earth bus shall be made continuous and necessary connectors and clamps for this purpose shall be included in the scope of supply of Contractor. Provision shall be made for extending the earth bus bars to future adjoining panels on either side.
- 10.2. Provision shall be made on each bus bar of the end panels for connecting Substation earthing grid. Necessary terminal clamps and connectors for this purpose shall be included in the scope of supply of Contractor.
- 10.3. All metallic cases of relays, instruments and other panel mounted equipment including gland plate, shall be connected to the earth bus by copper wires of size not less than 2.5 sq. mm. The colour code of earthing wires shall be green.
- 10.4. Looping of earth connections which would result in loss of earth connection to other devices when the loop is broken, shall not be permitted. However, looping of earth connections between equipment to provide alternative paths to earth bus shall be provided.
- 10.5. VT and CT secondary neutral or common lead shall be earthed at one place only at the terminal blocks where they enter the panel. Such earthing shall be made through links so that earthing may be removed from one group without disturbing continuity of earthing system for other groups.
- 10.6. An electrostatic discharge arrangement shall be provided in each panel so as to discharge human body before he handles the equipments inside the panels.

## 11. **INDICATING INSTRUMENTS & TRANSDUCERS FOR CONTROL**

## **PANEL:**

All instruments, meters and transducers shall be enclosed in dust proof, moisture resistant, black finished cases and shall be suitable for tropical use. All Megawatt, Megavar, voltage and frequency indicating instruments shall be provided with individual transducers and these shall be calibrated along with transducers to read directly the primary quantities. They shall be accurately adjusted and calibrated at works and shall have means of calibration check and adjustment at site. The supplier shall submit calibration certificates at the time of delivery. However no separate transducers are envisaged for digital bus voltmeters and digital frequency meters and the indicating meters provided in the synchronising equipment.

### **11.1. Indicating Instruments**

- 11.1.1. Unless otherwise specified, all electrical indicating instruments shall be of digital type suitable for flush mounting.
- 11.1.2. Instruments shall have 4-digit display; display height being not less than 25 mm.
- 11.1.3. Instrument shall conform to relevant IS and shall have an accuracy class of 1.5 or better. Watt and Var meters shall have an indication of (+) and (-) to indicate EXPORT and IMPORT respectively.
- 11.1.4. Digital voltage and frequency meters shall be of class: 0.5 and shall have digital display of **4** and **4.5** digits respectively, with display size, not less than 25mm (height).

### **11.2. Transducers**

- 11.2.1. Transducers (for use with Indicating Instruments and Telemetry/Data Communication application) shall in general conform to IEC:60688-1.
- 11.2.2. The transducers shall be suitable for measurement of active power, reactive power, voltage, current and frequency in three phase four wire unbalanced system.
- 11.2.3. The input to the transducers will be from sub-station current & potential transformers. The output shall be in milli ampere D.C. proportional to the input & it shall be possible to feed the output current directly to the telemetry terminal or indicating instruments.
- 11.2.4. The transducer characteristic shall be linear throughout the measuring range.
- 11.2.5. The transducer output shall be load independent.
- 11.2.6. The input & output of the transducer shall be galvanically isolated.
- 11.2.7. Each transducer shall be housed in a separate compact case and have suitable terminals for inputs & outputs.
- 11.2.8. The transducers shall be suitably protected against transient high peaks of voltage & current.
- 11.2.9. The transducer shall withstand indefinitely without damage and work satisfactorily at 120% of the rated voltage and 120% of the rated input

current as applicable.

- 11.2.10. All the transducers shall have an output of 4-20 mA.
- 11.2.11. The response time of the transducers shall be less than 1 second.
- 11.2.12. The accuracy class of transducers shall be 1.0 or better for voltage/current transducer, 0.5 or better for watt/VAR transducer and 0.2 or better for frequency transducer.
- 11.2.13. The transducers shall have a low AC ripple on output less than 1%.
- 11.2.14. The transducer shall have dual output.

## **12. ANNUNCIATION SYSTEM for Control Panel**

- 12.1. Alarm annunciation system shall be provided in the control board by means of visual and audible alarm in order to draw the attention of the operator to the abnormal operating conditions or the operation of some protective devices. The annunciation equipment shall be suitable for operation on the voltages specified in this specification.
- 12.2. The visual annunciation shall be provided by annunciation facia, mounted flush on the top of the control panels.
- 12.3. The annunciation facia shall be provided with translucent plastic window for alarm point with approximate size of 35mm x 50mm. The facia plates shall be engraved in black lettering with respective inscriptions. Alarm inscriptions shall be engraved on each window in not more than three lines and size of the lettering shall not be less than 5 mm.
- 12.4. Each annunciation window shall be provided with two white lamps in parallel to provide safety against lamp failure. Long life lamps shall be used. The transparency of cover plates and wattage of the lamps provided in the facia windows shall be adequate to ensure clear visibility of the inscriptions in the control room having high illumination intensity (350 Lux), from the location of the operator's desk.
- 12.5. All Trip facia shall have red colour and all Non-trip facia shall have white colour.
- 12.6. The audible alarm shall be provided by Buzzer/ Hooter /Bell having different sounds and shall be used as follows.

Hooter	Alarm Annunciation
Bell	Annunciation DC failure
Buzzer	AC supply failure
- 12.7. Sequence of operation of the annunciator shall be as follows :

<b>Sl. NO.</b>	<b>Alarm Condition</b>	<b>Fault Contact</b>	<b>Visual Annunciation</b>	<b>Audible Annunciation</b>
1.	Normal	Open	OFF	OFF
2.	Abnormal	Close	Flashing	ON
3.	Accept Push	Close	Steady On	OFF

	Button Pressed	Open	Steady On	OFF
4.	Reset Push Button Pressed	Close	On	OFF
		Open	Off	OFF
5.	Lamp Test Push Button Pressed	Open	Steady On	OFF

- 12.8. Audible annunciation for the failure of DC supply to the annunciation system shall be provided and this annunciation shall operate on 240 Volts AC supply. On failure of the DC to the annunciation system for more than 2 or 3 seconds (adjustable setting), a bell shall sound. A separate push button shall be provided for the cancellation of this audible alarm alone but the facia window shall remain steadily lighted till the supply to annunciation system is restored.
- 12.9. A separate voltage check relay shall be provided to monitor the failure of supply (240V AC) to the scheme mentioned in Clause above. If the failure of supply exists for more than 2 to 3 seconds, this relay shall initiate visual and audible annunciation. Visual and audible annunciation for the failure of AC supply to the annunciation system shall be provided and this annunciation shall operate on Annunciation DC and buzzer shall sound.
- 12.10. The annunciation system described above shall meet the following additional requirements :
- a) The annunciation system shall be capable of catering to at least 20 simultaneous signals at a time.
  - b) One set of the following push buttons shall be provided on each control panel:
    - Reset push button for annunciation system
    - Accept push button for annunciation system
    - Lamp test push button for testing the facia windows
  - c) One set of the following items shall be provided common for all the control panel (not applicable for extension of substation) :
    - Flasher relay for annunciation system
    - Push button for Flasher test
    - Three Push buttons for test of all audible alarm systems
  - d) These testing circuits shall be so connected that while testing is being done, it shall not prevent the registering of any new annunciation that may land during the test.
  - e) The annunciation shall be repetitive type and shall be capable of registering the fleeting signal. Minimum duration of the fleeting signal registered by the system shall be 15 milli seconds.
  - f) In case of static annunciator scheme, special precaution shall be taken to ensure that spurious alarm condition does not appear due to

influence of external electromagnetic/ electrostatic interference on the annunciator wiring and switching disturbances from the neighbouring circuits within the panels and the static annunciator shall meet the high voltage susceptibility test , impulse voltage with stand test , high frequency disturbance test– class III and fast transient disturbance test –level III as per IEC 60255.

12.11. The annunciation system to be supplied for existing sub-stations shall be engineered as an extension to the existing scheme.

12.12. **For the Control panel with BCU (if envisaged in section-Project), only common alarm lamp shall be provided for each Control panel. Each BCU of the control panel shall energize this common alarm lamp on occurrence of alarms/Trips. All alarms shall be available in the BCU mimic/HMI.**

### 13. SWITCHES

13.1. Control and instrument switches shall be rotary operated type with escutcheon plates clearly marked to show operating position and circuit designation plates and suitable for flush mounting with only switch front plate and operating handle projecting out.

13.2. The selection of operating handles for the different types of switches shall be as follows :

Breaker, Isolator control switches : Pistol grip, black

Synchronising switches : Oval, Black, Keyed handle (one common removable handle for a group of switches or locking facility having common key)

synchronising Selector switches : Oval or knob, black

Instrument switches : Round, knurled, black

Protection Transfer switch, : Pistol grip, lockable and black.

**Local / remote selector switch**

13.3. The control switch of breaker and isolator shall be of spring return to neutral type. The switch shall have spring return from close and trip positions to "after close" and "after trip" positions respectively.

13.4. **Protection Transfer switch / BCU will energise a bi-stable relay for protection transfer function from local/ remote HMI.**

13.5. Instrument selection switches shall be of maintained contact (stay put) type. Ammeter selection switches shall have make-before-break type contacts so as to prevent open circuiting of CT secondary when changing the position of the switch. Voltmeter transfer switches for AC shall be suitable for reading all line- to-line and line-to-neutral voltages for non- effectively earthed systems and for reading all line to line

voltages for effectively earthed systems.

- 13.6. Synchronising switches shall be of maintained contact (stay put) type having a common removable handle for a group of switches. The handle shall be removable only in the OFF position and it shall be co-ordinated to fit in to all the synchronising switches. These switches shall be arranged to connect the synchronising equipment when turned to the 'ON' position. One contact of each switch shall be connected in the closing circuit of the respective breaker so that the breaker cannot be closed until the switch is turned to the 'ON' position.
- 13.7. Lockable type of switches which can be locked in particular positions shall be provided when specified. The key locks shall be fitted on the operating handles.
- 13.8. The contacts of all switches shall preferably open and close with snap action to minimise arcing. Contacts of switches shall be spring assisted and contact faces shall be with rivets of pure silver or silver alloy. Springs shall not be used as current carrying parts
- 13.9. The contact combination and their operation shall be such as to give completeness to the interlock and function of the scheme.
- 13.10. The contact rating of the switches shall be as follows :

Description	Contact Rating in Amps		
	220V DC	50V DC	240V AC
Make and carry continuously	10	10	10
Make and carry for 0.5 sec.	30	30	30
Break for Resistive load	3	20	7
Break for Inductive load with L/R = 40m sec.	0.2	-	-

#### 14. INDICATING LAMPS

- 14.1. Indicating lamps shall be of cluster LED type suitable for panel mounting with rear terminal connections. Lamps shall be provided with series connected resistors preferably built in the lamp assembly. Lamps shall have translucent lamp covers to diffuse lights coloured red, green, amber, clear white or blue as specified. The lamp cover shall be preferably of screwed type, unbreakable and moulded from heat resisting material.

- 14.2. The lamps shall be provided with suitable resistors.
- 14.3. Lamps and lenses shall be interchangeable and easily replaceable from the front of the panel. Tools, if required for replacing the bulbs and lenses shall also be included in the scope of the supply.
- 14.4. The indicating lamps with resistors shall withstand 120% of rated voltage on a continuous basis.

**15. POSITION INDICATORS (if Applicable)**

- 15.1. Position indicators of "SEMAPHORE" type shall be provided when specified as part of the mimic diagrams on panels for indicating the position of circuit breakers, isolating/earthing switches etc. The indicator shall be suitable for semi-flush mounting with only the front disc projecting out and with terminal connection from the rear.
- 15.2. Position indicator shall be suitable for DC Voltage as specified. When the supervised object is in the closed position, the pointer of the indicator shall take up a position in line with the mimic bus bars, and at right angles to them when the object is in the open position. When the supply failure to the indicator occurs, the pointer shall take up an intermediate position to indicate the supply failure.
- 15.3. The rating of the indicator shall not exceed 2.5 W.
- 15.4. The position indicators shall withstand 120% of rated voltage on a continuous basis.

**16. SYNCHRONISING EQUIPMENT**

- 16.1. For sub-station equipped with sub-station Automation system, the requirement of synchronisation is specified in section Sub-station Automation System and the same shall prevail. For other sub-station which is not equipped with sub-station automation system following shall be applicable as per requirement.
- 16.2. The synchronising instruments shall be mounted either on a synchronising trolley or on a synchronising panel. The panel/ trolley shall be equipped with double analog voltmeters and double analog frequency meters, synchroscope and lamps fully wired. The size of voltmeters and frequency meters provided in the synchronising panel shall not be less than 144 X 144 sq. mm. Suitable auxiliary voltage transformers wherever necessary shall also be provided for synchronising condition. In case the synchroscope is not continuously rated, a synchroscope cut-off switch shall be provided and an indicating lamp to indicate that the synchroscope is energised, shall also be provided.
- 16.3. Synchronising check relay with necessary ancillary equipment's shall be provided which shall permit breakers to close after checking the requirements of synchronising of incoming and running supply. The phase angle setting shall not exceed 35 degree and have voltage difference setting not exceeding 10%. This relay shall have a response

time of less than 200 milliseconds when the two system conditions are met within present limits and with the timer disconnected. The relay shall have a frequency difference setting not exceeding 0.45% at rated value and at the minimum time setting. A guard relay shall be provided to prevent the closing attempt by means of synchronising check relay when control switch is kept in closed position long before the two systems are in synchronism

- 16.4. The synchronising panel shall be draw out and swing type which can be swivelled in left and right direction. The synchronising panel shall be placed along with control panels and the number of synchronising panel shall be as indicated in BPS. The incoming and running bus wires of VT secondary shall be connected and run as bus wires in the control panels and will be extended to synchronising panel for synchronisation of circuit breakers. The selector switch provided for each circuit breaker in respective control panels shall be lockable type with a common key so that only one selector switch is kept in synchronising mode at a time.
- 16.5. Alternatively, the trolley shall be of mobile type with four rubber-padding wheels capable of rotating in 360 degree around the vertical axis. Suitable bumpers with rubber padding shall be provided all around the trolley to prevent any accidental damage to any panel in the control room while the trolley is in movement. The trolley shall have two meter long flexible cord fully wired to the instruments and terminated in a plug in order to facilitate connecting the trolley to any of the panels. The receptacle to accept the plug shall be provided on the panel.
- 16.6. At existing sub-stations, the synchronising scheme shall be engineered to be compatible with the existing synchronising scheme and synchronising socket/switch on the panel. In substations, where synchronising panels are available, the bidder shall carry out the shifting of the above panels, if required, to facilitate the extension of control panel placement.

## 17. RELAYS

- 17.1. All relays shall conform to the requirements of IS: 3231/IEC-60255/IEC 61000 or other applicable standards. Relays shall be suitable for flush or semi-flush mounting on the front with connections from the rear.
- 17.2. All protective relays shall be of numerical type and communication protocol shall be as per IEC 61850. **Protective relays shall also fulfil the requirements specified for Protection IEDs in Section-Substation automation system**
- 17.3. All protective relays shall be in draw out or plug-in type/modular cases with proper testing facilities. Necessary test plugs/test handles shall be supplied loose and shall be included in contractor's scope of supply.
- 17.4. All AC operated relays shall be suitable for operation at 50 Hz. AC Voltage operated relays shall be suitable for 110 Volts VT secondary and current operated relays for 1 amp CT secondary. All DC operated relays and timers shall be designed for the DC voltage specified, and shall operate satisfactorily between 80% and 110% of rated voltage. Voltage

operated relays shall have adequate thermal capacity for continuous operation.

- 17.5. The protective relays shall be suitable for efficient and reliable operation of the protection scheme described in the specification. Necessary auxiliary relays and timers required for interlocking schemes for multiplying of contacts suiting contact duties of protective relays and monitoring of control supplies and circuits, lockout relay monitoring circuits etc. also required for the complete protection schemes described in the specification shall be provided. All protective relays shall be provided with at least two pairs of potential free isolated output contacts. Auxiliary relays and timers shall have pairs of contacts as required to complete the scheme; contacts shall be silver faced with spring action. Relay case shall have adequate number of terminals for making potential free external connections to the relay coils and contacts, including spare contacts.
- 17.6. Timers shall be of solid state/numerical type. Time delay in terms of milliseconds obtained by the external capacitor resistor combination is not preferred and shall be avoided.
- 17.7. No control relay, which shall trip the power circuit breaker when the relay is de-energised, shall be employed in the circuits.
- 17.8. Provision shall be made for easy isolation of trip circuits of each relay for the purpose of testing and maintenance.
- 17.9. Auxiliary seal-in-units provided on the protective relays shall preferably be of shunt reinforcement type. If series relays are used the following shall be strictly ensured:
  - (a) The operating time of the series seal-in-unit shall be sufficiently shorter than that of the trip coil or trip relay in series with which it operates to ensure definite operation of the flag indicator of the relay.
  - (b) Seal-in-unit shall obtain adequate current for operation when one or more relays operate simultaneously.
  - (c) Impedance of the seal-in-unit shall be small enough to permit satisfactory operation of the trip coil on trip relays when the D.C. Supply Voltage is minimum.
  - (d) Trip-circuit seal-in is required for all trip outputs, irrespective of the magnitude of the interrupted current. The trip-circuit seal-in logic shall not only seal-in the trip output(s),but also the relevant initiation signals to other scheme functions, (e.g. initiate signals to the circuit-breaker failure function, reclosing function etc.), and the alarm output signals.
  - (e) Two methods of seal-in are required, one based on the measurement of AC current, catering for those circumstances for which the interrupted current is above a set threshold, and one based on a fixed time duration, catering for those circumstances for which the interrupted current is small (below the set threshold).
  - (f) For the current seal-in method, the seal-in shall be maintained until the circuit-breaker opens, at which time the seal-in shall reset and the seal-

in method shall not now revert to the fixed time duration method. For this seal-in method, the seal-in shall be maintained for the set time duration. For the line protection schemes, this time duration shall be independently settable for single- and three-pole tripping.

- (g) Seal-in by way of current or by way of the fixed duration timer shall occur irrespective of whether the trip command originates from within the main protection device itself (from any of the internal protection functions), or from an external device with its trip output routed through the main protection device for tripping. Trip-circuit seal-in shall not take place under sub-harmonic conditions (e.g. reactor ring down).
- 17.10. The setting ranges of the relays offered, if different from the ones specified shall also be acceptable if they meet the functional requirements.
- 17.11. Any alternative/additional protections or relays considered necessary for providing complete effective and reliable protection shall also be offered separately. The acceptance of this alternative/ additional equipment shall lie with the POWERGRID/Employer.
- 17.12. All relays and their drawings shall have phase indications as R-Red, Y-yellow, B-blue
- 17.13. For numerical relays, the scope shall include the following:
  - a) Necessary software and hardware to up/down load the data to/from the relay from/to the personal computer installed in the substation. However, the supply of PC is not covered under this clause.
  - b) The relay shall have suitable communication facility for future connectivity to SCADA. The relay shall be capable of supporting IEC 61850 protocol.
  - c) In case of line protection and transformer/reactor protection, the features like fault recorder and event logging function as available including available as optional feature in these relays shall be supplied and activated at no extra cost to the owner. Also necessary software/ hardware for automatic uploading to station HMI/DR work station (as applicable) shall be supplied. It is to be clearly understood that these shall be in addition to Fault recorder function as specified at clause no. 28.

## **18. TRANSMISSION LINE PROTECTION**

- 18.1. All relays shall be suitable for series compensated line.
- 18.2. The line protection relays are required to protect the line and clear the faults on line within shortest possible time with reliability, selectivity and full sensitivity to all type of faults on lines. The general concept is to have two main protections having equal performance requirement specially in respect of time as called Main-I and Main-II for 765kV, 400KV and 220KV transmission lines and Main and back up protection for 132 KV transmission lines.
- 18.3. The Transmission system for which the protection equipment are required is indicated in Section – Project.

- 18.4. The maximum fault current could be as high as 63kA but the minimum fault current could be as low as 20% of rated current of CT secondary. The starting & measuring relays characteristics should be satisfactory under these extremely varying conditions.
- 18.5. The protective relays shall be suitable for use with capacitor voltage transformers having non-electronic damping and transient response as per IEC.
- 18.6. Fault Recorder, Distance to fault Locator and Over voltage relay (stage - 1/2) functions if offered as an integral part of line protection relays, shall be acceptable provided these meet the technical requirements as specified in the respective clauses.
- 18.7. Auto reclose relay function if offered as an integral part of line distance protection relay, shall be acceptable for **132kV & below lines** only provided the auto reclose relay feature meets the technical requirements as specified in the respective clause.
- 18.8. The following protections shall be provided for each of the Transmission lines:

**For 765kV, 400kV & 220kV Lines**

**Main-I:** Distance protection scheme.

**Main-II:** Distance protection scheme

- **If specified in Section-Project, Main-I and / or Main-II relay shall be provided as Line differential protection relay with built in distance function. Further, matching Line differential protection relays for remote ends shall be provided as per Bid Price Schedule (BPS).**
- **Main-I & Main-II relay shall be of different make & model. Same make relay shall be acceptable only if they are of different hardware & manufacturing platform.**
- If specified in the "Section- Project, "back up Over current and Earth fault protection shall be provided instead of Main -II protection scheme for 220KV lines to match with requirements at the remote ends.

**For 132KV**

**Main:** Distance protection scheme

**Back up:** Directional Over Current and Earth fault Protection

The detailed description of line protections is given here under.

- 18.9. **Main-I and Main-II Distance Protection scheme:**
- (a) shall have continuous self monitoring and diagnostic feature

- (b) shall be non-switched type with separate measurements for all phase to phase and phase to ground faults
- (c) shall have stepped time-distance characteristics and independent **three forward zones and one reverse/offset** zone
- (d) shall have mho or quadrilateral or other suitably shaped characteristics for **all zones**.
- (e) shall have following maximum operating time (including trip relay time, if any) under given set of conditions and with CVT being used on line (with all filters included)

<b>(i) for 765 KV, 400 KV &amp; 220 KV lines:</b>		
<b>For Source to Impedance ratio:</b>	<b>4</b>	<b>15</b>
Relay setting (Ohms)	(10 or 20) and 2	2
Fault Locations (as % of relay setting)	50	50
Fault resistance (Ohms)	0	0
Maximum operating time (Milliseconds )	40 for all faults	45 for 3 ph. Faults & 60 for all other faults
<b>(ii) for 132 KV lines:</b>		
A relaxation of 5 ms in above timings is allowed for 132 KV lines.		

- (f) The relay shall have an adjustable characteristics angle setting range of 30-85 degree or shall have independent resistance(R) and reactance (X) setting.
- (g) shall have two independent continuously variable time setting range of 0-3 seconds for zone-2 and 0-5 seconds for zone-3/reverse zone.
- (h) shall have resetting time of less than 55 milli-seconds (including the resetting time of trip relays)
- (i) shall have variable residual compensation for each zone
- (j) shall have memory techniques with defined characteristics in all three phases to ensure correct operation during close-up 3 phase faults and other adverse conditions and shall operate instantaneously when circuit breaker is closed to zero-volt 3 phase fault
- (k) shall have weak end in-feed feature
- (l) shall be suitable for single & three phase tripping
- (m) shall have a continuous current rating of two times of rated current. The voltage circuit shall be capable of operation at 1.2 times rated voltage. The relay shall also be capable of carrying a high short time current of 70 times rated current without damage for a period of 1 sec.
- (n) shall be provided with necessary self reset type trip duty contacts for

completion of the scheme (Minimum number of these trip duty contacts shall be four per phase) either through built in or through separate high speed trip relays. Making capacity of these trip contacts shall be 30 amp for 0.2 seconds with an inductive load of L/R > 10 milli seconds. If separate high speed trip relays are used, the operating time of the same shall not be more than 10 milliseconds

- (o) shall be suitable for use in permissive under reach/ over reach/ blocking communication mode
- (p) shall have suitable number of potential free contacts for Carrier aided Tripping, Auto reclosing, CB failure, Disturbance/**Fault** recorder & Data acquisition system
- (q) include power swing blocking **and out-of-step** protection which shall
  - have suitable setting range to encircle the distance protection described above
  - block tripping **of distance function zones** during power swing conditions
  - release blocking in the event of actual fault
  - **release tripping on detection of out-of-step power swing condition**

**Alternatively standalone relay for out of step protection shall also be acceptable, if the same is not part of main protection relays.**

- (r) include fuse failure protection which shall monitor all the three fuses of C.V.T. and associated cable against open circuit
  - inhibit trip circuits on operation and initiate annunciation
  - have an operating time less than 7 milliseconds
  - remain inoperative for system earth faults
- (s) include a directional back up Inverse Definite Minimum Time (IDMT) earth fault relay with normal inverse characteristics as per IEC 60255-3 as a built in feature or as a separate unit for 765kV, 400 KV and 220KV transmission lines
- (t) Must have a current reversal guard feature.
- (u) **Shall have Stub protection function with current setting minimum range of 1 to 3 pu with definite time delay setting minimum range of 0 to 100msec.**
- (v) **have feature of load encroachment blinder to safeguard the protection trip during heavy line loading condition.**

#### 18.10. **Line Differential Relay protection scheme (If applicable)**

The line current differential relay with built-in distance protection function shall be capable of being selected to differential function with back up distance function or shall activate back up distance automatically when the differential relay is out of service. The relay shall fulfil the requirement

specified above at clause 18.9 for distance relay function.

Further, the line current differential function shall conform to the following main requirements:

- i.** The current differential shall be a unit system of protection.
- ii.** The line Current differential Protection shall comprise a well-proven high-speed phase segregated numerical current differential protection scheme, which shall be designed for the selective protection of the EHV network.
- iii.** The High speed numerical current differential protection shall be suitable to work through directly connected fiber optics and the relay shall have the requisite teleprotection communication capability.
- iv.** Shall have built-in signalling modules for communication with the remote end relay via direct optical fiber cables.
- v.** The contractor shall coordinate the requirements of the current differential relay with the communication system in order to ensure compatibility between the two.
- vi.** The relay shall incorporate inter-tripping, VT Supervision functions and heavy duty contacts for tripping of the feeder circuit breaker as well as provide all flagging, alarms etc.
- vii.** Shall have high-speed fault detection capability with typical relay operation time of less than **30 ms** for 765kV/400kV/220kV line faults and less than 40 ms for 132kV & below.
- viii.** Shall have high sensitivity for all types of faults.
- ix.** Shall detect and clear faults along the whole length of the feeder within the specified operating time when the remote end breaker is open or there is a weak in feed.
- x.** Shall remain stable for fault on a parallel feeder under subsequent current reversal in the healthy feeder due to slow opening of one of the faulty feeder's circuit breakers.
- xi.** Shall not be affected by heavy load transfer, power swings, CT saturation, distorted primary currents and voltages, VT fuse failure, line charging currents external switching, arc or tower footing resistance, sudden power reversal, zero sequence mutual coupling, fault resistance and out of phase source at the two line terminals producing misleading apparent fault reactance, power frequency variations, collapse of voltage on the faulted phase(s), etc.
- xii.** Shall have features to clear close in faults at high speed in the event of failure of signalling channel.
- xiii.** Shall have features to test at one end all the functions associated with the protection, without the presence of personnel at the remote end.
- xiv.** Shall have features to block relay in case of signalling channel

failure or remote relay out of service / block or setting mismatch or dc failure etc., to avoid inadvertent tripping and shall produce alarm during blocking.

- xv. Shall have inter-tripping compliant with IEC60834-1 and IEC60834-2 respectively for signalling as appropriate.
- xvi. The line differential device address shall be settable and shall be suitable to set for no. of feeders shown in SLD.
- xvii. CT supervision / VT Supervision shall be configured to initiate alarm locally and to sub-station automation system or event recorder as per requirement.
- xviii. Shall have single pole/three pole tripping feature.
- xix. Shall have built-in SOTF logic feature.
- xx. Shall have features to block auto-reclose internally or externally at local end and facility to send blocking signals to remote end relay internally (through FO communication channels) during SOTF trips.
- xxi. Shall have facility to configure signal transferred between local and remote end relays in the internal event recorder and disturbance recorder.
- xxii. Shall have configurable time delayed thermal protection element and back up earth fault protection element.
- xxiii. Shall have following features:
  - Satisfactory Performance of relay under CT saturation during through faults.
  - Satisfactory Performance of relay under conditions of CT saturation for in zone faults.
  - Satisfactory Performance of relay during transient (jitter) and permanent changes in signalling propagation delays.
- xxiv. Shall include necessary Optical fibre cable & associated accessories for connection between the current differential relay panel and existing Fibre optic distribution panel (FODP).

18.11. **Back-up Directional Over Current and Earth fault protection scheme**

- (a) shall have three over current and one earth fault element(s) which shall be either independent or composite unit(s)
- (b) shall include necessary VT fuse failure relays for alarm purposes
- (c) **over current elements** shall
  - have IDMT characteristic (normal inverse as per IEC)
  - have a variable setting range of 50-200% of rated current
  - have a characteristic angle of 30/45 degree lead
  - include hand reset flag indicators or LEDs

- (d) **earth fault element** shall
- have IDMT characteristic (normal inverse as per IEC)
  - have a variable setting range of 20-80% of rated current
  - have a characteristic angle of 45/60 degree lag
  - include hand reset flag indicators or LEDs
  - include necessary separate interposing voltage transformers or have internal feature in the relay for open delta voltage to the relay

18.12. **LINE OVER VOLTAGE PROTECTION RELAY** shall

- (a) monitor all three phases
- (b) have two independent stages
- (c) **be either a standalone relay for both stage-I & II or as built in function of Main-I & Main-II distance relay for both stage-I & II.**
- (d) have an adjustable setting range of 100-170% of rated voltage **with a setting least count of 0.1V (Secondary volts) and** an adjustable time delay range of 1 to 60 seconds for the first stage.
- (e) have an adjustable setting range of 100-170% of rated voltage with a time delay of 100-200 mill seconds for the second stage.
- (f) be tuned to power frequency
- (g) provided with separate operation indicators (flag target) and **signal** for each stage relays **with phase indication for event logging.**
- (h) have a drop-off to pick-up ratio greater than **97%**

18.13. All trip relays used in transmission line protection scheme shall be of self/electrical reset type depending on application requirement.

19. **CIRCUIT BREAKER PROTECTION:**

This shall include following functions:

19.1. **Numerical AUTO RECLOSING** function shall

- (a) have single phase reclosing facilities
- (b) have a continuously variable single phase dead time range of 0.1-2 seconds
- (c) have a continuously variable reclaim time range of 5-300 seconds
- (d) Incorporate a two position selector switch, from which single phase auto-reclosure and non-auto reclosure mode can be selected. Alternatively, the mode of auto reclosing can be selected through **HMI of the relay or BCU & SAS.**
- (e) be of single shot type
- (f) have priority circuit for closing of both circuit breakers in case of one and half breaker arrangements to allow sequential closing of breakers
- (g) However, Auto-reclose as in built function of bay controller unit (BCU)

(if supplied) is also acceptable **provided the signal exchange for auto-reclose function from BCU to main Relays & vice-versa is achieved through hardwiring.**

19.2. **LOCAL BREAKER BACK-UP (LBB) PROTECTION SCHEME** shall

- (a) be triple pole type
- (b) have an operating time of less than 15 milli seconds
- (c) have a resetting time of less than 15 milli seconds
- (d) have three over current elements
- (e) be arranged to get individual initiation from the corresponding phase of main protections of line for each over current element. However, common three phase initiation is acceptable for other protections and transformer /reactor equipment protections
- (f) have a setting range of 10-80% of rated current
- (g) have a continuous thermal withstand two times rated current irrespective of the setting
- (h) have a timer with continuously adjustable setting range of 0.1-1 seconds
- (i) have necessary auxiliary relays to make a comprehensive scheme
- (j) **Shall have re-trip feature for tripping its own CB after initiation with a set time delay.**
- (k) **be acceptable as Built-in protection function of distributed bus bar protection scheme only; however in that case separate LBB relay shall be provided for tie bays.**
- (l) be similar relays for complete scope of work as per specification **(if provided as standalone relay unit).**

20. **REACTOR PROTECTION**

20.1. **Differential Protection Relay** shall

- (a) be triple pole type
- (b) have operation time less than 25 milli-seconds at 5 times setting
- (c) be tuned to system frequency
- (d) have current setting range of 10 to 40% of 1 Amp. or a suitable voltage setting range
- (e) be high impedance / biased differential type
- (f) be stable for all external faults, CT saturation.

20.2. **Restricted Earth Fault Protection Relay** shall

- (a) be single pole type
- (b) be of current/voltage operated high impedance type

- (c) have a current setting of **05-40%** of 1 Amp./have a suitable voltage setting range
- (d) be tuned to system frequency
- (e) have a suitable non-linear resistor to limit the peak voltage to 1000 Volts
- (f) **Separate relay shall be provided for 1-phase spare reactor unit (if envisaged).**

20.3. **Back up impedance protection Relay shall**

- (a) be triple pole type, with faulty phase identification/ indication
- (b) be single step polarised 'mho' distance/ impedance relay suitable for measuring phase to ground and phase to phase faults
- (c) have adequate ohmic setting range to cover at least 60% of the impedance of the reactor and shall be continuously variable
- (d) have an adjustable characteristic angle of 30-80 degree
- (e) have a definite time delay relay with a continuously adjustable setting range of 0.2-2.0 seconds
- (f) include VT failure relay which shall block the tripping during VT fuse failure condition
- (g) **have Back-up over current and earth fault protection as built in function**

20.4. Further, Reactor auxiliary protections contacts (Buchholz, PRV, Oil Temperature, Winding Temperature etc.) can be wired suitably in above protections or provide separate Flag relays/Auxiliary relays as per scheme requirements. **Further reactor protections shall be grouped such that Differential protection, Buchholz-I trip and Winding temperature trip are on DC-A while REF protection, Back-up Impedance protection, PRD-I and Oil temperature trip are on DC-B. In case multiple trip contacts for Buchholz relay / PRD relays are available, then their contacts shall be wired to both Group of Protection.**

21. **TRANSFORMER PROTECTION**

21.1. **Transformer differential protection** scheme shall

- (a) be triple pole type, with faulty phase identification/ indication
- (b) have an operating time not greater than 30 milli seconds at 5 times the rated current
- (c) have three instantaneous high set over-current units
- (d) **be bias differential type having** an adjustable bias setting range of 10-50%
- (e) be suitable for **04 nos. of 3-ph CT input** with rated **CT secondary** current of 1 Amp.
- (f) have second harmonic or other inrush proof features and also

should be stable under normal over fluxing conditions. Magnetising inrush proof feature shall not be achieved through any intentional time delay e.g. use of timers to block relay operation or using disc operated relays

- (g) have an operating current setting of 15% or less
- (h) include necessary separate interposing current transformers for angle and ratio correction or have internal feature in the relay to take care of the angle & ratio correction
- (i) have a fault recording feature to record graphic form of instantaneous values of following analogue channels during faults and disturbances for the pre fault and post fault period:

Current in all three windings in nine / **twelve** analogue channels in case of 400kV class / **765kV class** respectively or 6 analogue channels for lower voltage transformers and Voltage in one channel

The disturbance recorder **function built in the Differential protection IED** shall have the facility to record the following external digital channel signals associated with transformer **which shall be wired to differential relay** apart from the digital signals pertaining to differential relay:

1. REF protection operated
2. HV Breaker status (Main & tie/transfer both separately)
3. IV Breaker status (Main & tie/transfer both separately)
4. **Bucholz / OLTC/ WTI/ OTI alarm**
5. **Bucholz / PRD / SPR/ Trip**
6. **Group-A, Group-B lock-out relay trip**

Necessary hardware and software, for automatic up-loading the data captured by disturbance recorder to the personal computer (DR Work Station) available in the substation, shall be included in the scope.

## 21.2. **Over Fluxing Protection Relays** shall

- (a) operate on the principle of Voltage to frequency ratio and shall be phase to phase connected
- (b) have inverse time characteristics, matching with transformer over fluxing withstand capability curve
- (c) provide an independent 'alarm' with the time delay continuously adjustable between 0.1 to 6.0 seconds at values of 'v/f' between 100% to 130% of rated values
- (d) tripping time shall be governed by 'v/f' Versus time characteristics of the relay
- (e) have a set of characteristics for Various time multiplier settings. The maximum operating time of the relay shall not exceed 3 seconds and 1.5 seconds at 'v/f' values of 1.4 and 1.5 times, the

rated values, respectively.

- (f) have an accuracy of operating time, better than  $\pm 10\%$
- (g) have a resetting ratio of **97 %** or better.

21.3. **Restricted Earth Fault Protection shall**

- (a) be single pole type
- (b) be of current/voltage operated type
- (c) have a current setting range of **5-40%** of 1 Amp./ have a suitable voltage setting range
- (d) be tuned to the system frequency
- (e) **be phase segregated type for 1-ph transformer units**
- (f) **Separate relay shall be provided for 1-phase spare transformer unit (if envisaged).**

21.4. **Back-up Over Current and Earth fault protection scheme with high set feature**

- (a) Shall have three over current and one earth fault element(s) which shall be either independent or composite unit(s).
- (b) The scheme shall include necessary VT fuse failure relays for alarm purposes
- (c) Over current relay shall
  - have directional IDMT characteristic with a definite minimum time of 3.0 seconds at 10 times setting and have a variable setting range of 50-200% of rated current
  - have low transient, over reach high set instantaneous unit of continuously variable setting range 500-2000 % of rated current
  - have a characteristic angle of 30/45 degree lead
  - include hand reset flag indicators or LEDs.
- (d) Earth fault relay shall
  - have directional IDMT characteristic with a definite minimum time of 3.0 seconds at 10 times setting and have a variable setting range of 20-80% of rated current
  - have low transient, over reach high set instantaneous unit of continuously variable setting range 200-800 % of rated current
  - have a characteristic angle of 45/60 degree lag
  - include hand reset flag indicators or LEDs
  - include necessary separate interposing voltage

transformers or have internal feature in the relay for open delta voltage to the relay

- 21.5. **Transformer Overload Protection Relay** shall
- (a) be of single pole type
  - (b) be of definite time over-current type
  - (c) have one set of over-current relay element, with continuously adjustable setting range of 50-200% of rated current
  - (d) have one adjustable time delay relay for alarm having setting range of 1 to 10.0 seconds, continuously.
  - (e) have a drop-off/pick-up ratio greater **than 95%**.
- 21.6. **Transformer Neutral Current Protection relay** (for 1-Phase transformer bank neutral) shall
- (a) have directional IDMT characteristic with a definite minimum time of 3.0 seconds at 10 times setting and have a variable setting range of 20-80% of rated current.
- 21.7. Further, Transformer auxiliary protections contacts (Buchholz, PRD, **SPRD**, Oil Temperature, Winding Temperature, OLTC Buchholz etc. can be wired suitably in above protections or provide separate Flag relays/Auxiliary relays as per scheme requirements. **Further, transformer protections shall be grouped such that Differential trip, Buchholz-I trip, Oil temperature alarm and Winding temperature trip are on DC source-A while REF trip, Buchholz alarm, PRD-I trip, winding temperature alarm and Oil temperature trip are on DC source-B. In case multiple trip contacts for Buchholz relay / PRD relays are available, then their contacts shall be wired to both Group of Protection.**

## 22. **TEE DIFFERENTIAL PROTECTION RELAYS (If Applicable)**

- 22.1. **TEE-1 Differential (Bias) protection relay** shall
- (a) be triple pole type
  - (b) have an operating time less than 30 milliseconds at 5 times the rated current
  - (c) have three instantaneous high set over current units
  - (d) have an adjustable bias setting range of 20-50%
  - (e) have an operating current setting of 15% of 1 Amp or less
- 22.2. **TEE-2 Differential (High Impedance) Protection relay** shall
- (a) be triple pole type
  - (b) have operating time less than 25 milliseconds at 5 times setting

- (c) be tuned to system frequency
- (d) have current setting range of 20 to 80% of 1 Amp
- (e) be voltage operated, high impedance type
- (f) be stable for all external faults
- (g) be provided with suitable non linear resistors across the relay to limit the peak voltage to 1000 volts

23. **TRIP CIRCUIT SUPERVISION RELAY**

- (a) The relay shall be capable of monitoring the healthiness of each 'phase' trip-coil and associated circuit of circuit breaker during 'ON' and 'OFF' conditions.
- (b) The relay shall have adequate contacts for providing connection to alarm and event logging.
- (c) The relay shall have time delay on drop-off of not less than 200 milli seconds and be provided with operation indications for each phase

24. **TRIPPING RELAY**

High Speed Tripping Relay shall

- (a) be instantaneous (operating time not to exceed 10 milli-seconds).
- (b) reset within 20 milli seconds
- (c) be D.C. operated
- (d) have adequate contacts to meet the requirement of scheme, other functions like auto-reclose relay, LBB relay as well as cater to associated equipment like event logger (SAS), Disturbance recorder, fault Locator, etc.
- (e) be provided with operation indicators for each element/coil.

25. **DC SUPPLY SUPERVISION RELAY**

- (a) The relay shall be capable of monitoring the failure of D.C. supply to which, it is connected.
- (b) It shall have adequate potential free contacts to meet the scheme requirement.
- (c) The relay shall have a 'time delay on drop-off' of not less than 100 milli seconds and be provided with operation indicator/flag.

26. **BUS BAR PROTECTION**

26.1. Redundant (1+1) numerical **low impedance biased differential** Bus Bar protection scheme for each Main bus (Bus1 / Bus2) & Transfer Bus (as applicable) for 400kV and 765kV shall be provided. The scheme shall be engineered so as to ensure that operation of any one out of two schemes connected to faulty bus shall result in tripping of the same.

26.2. Single bus bar protection scheme shall be provided for each main bus and transfer bus (as applicable) for 220KV and 132 KV voltage levels.

- 26.3. Each Bus Bar protection scheme shall
- (a) have maximum operating time up to trip impulse to trip relay of 25 milli seconds at 5 times setting value for all types of faults.
  - (b) operate selectively for each bus bar
  - (c) give hundred percent security up to 63 KA fault level for 400KV and 220KV and 31.5 KA for 132 KV system.
  - (d) incorporate continuous supervision for CT secondary against any possible open circuit and if it occurs, shall render the relevant zone of protection inoperative and initiate an alarm.
  - (e) not give false operation during normal load flow in bus bars
  - (f) not cause tripping for the differential current below the load current of heaviest loaded feeder. Contractor shall submit application check for the same.
  - (g) be of phase segregated and triple pole type
  - (h) incorporate clear zone indication
  - (i) provide independent zones of protection (including transfer bus if any). If the bus section is provided then each side of bus section shall have separate set of bus bar protection schemes
  - (j) include protection 'IN/OUT' switch for each zone
  - (k) include individual high speed electrically reset tripping relays for each feeder. However, in case of distributed Bus bar protection, individual trip relay shall not be required if bay unit is having trip duty contacts for breaker tripping.
  - (l) be transient free in operation
  - (m) include continuous D.C. supplies supervision
  - (n) shall include necessary C.T. switching relays wherever C.T. switching is involved and have 'CT' selection incomplete alarm
  - (o) shall include trip relays, CT switching relays (if applicable), auxiliary CTs (if applicable) as well as additional power supply modules, input modules etc. as may be required to provide a Bus-bar protection scheme for the complete bus arrangement i.e. for all the bays or breakers including future bays as per the Single line diagram for new substations. However for extension of bus bar protection scheme in existing substations, scope shall be limited to the bay or breakers **covered in the scope of work**. Suitable panels (if required) to mount these are also included in the scope of the work.
  - (p) In case of distributed Bus bar Protection, the bay units for future bays may be installed in a separate panel and the same shall be located in switchyard panel room where bus bar protection panel shall be installed.
- 26.4. At existing substations, Bus-bar protection scheme with independent zones for each bus, will be available. All necessary co-ordination for

'AC' and 'DC' interconnections between existing schemes (Panels) and the bays proposed under the scope of this contract shall be fully covered by the bidder. Any auxiliary relay, trip relay, flag relay and multi tap auxiliary CTs (in case of biased differential protection) required to facilitate the operation of the bays covered under this contract shall be fully covered in the scope of the bidder.. .

- 26.5. The test terminal blocks (TTB) to be provided shall be fully enclosed with removable covers and made of moulded, non-inflammable plastic material with boxes and barriers moulded integrally. All terminals shall be clearly marked with identification numbers or letters to facilitate connection to external wiring. Terminal block shall have shorting, disconnecting and testing facilities for CT circuits.

**27. WEATHER PROOF RELAY PANELS (For CT switching, If Applicable)**

- (a) This panel shall include necessary number of electrically reset relays each with at least eight contacts for isolator auxiliary contacts multiplication and for changing the CT and DC circuits to relevant zones of bus bar protection.
- (b) The panel shall be sheet steel enclosed and shall be dust, weather and vermin proof. Sheet steel used shall be at least 2.0 mm thick and properly braced to prevent wobbling.
- (c) The enclosures of the panel shall provide a degree of protection of not less than IP-55 (as per IS: 2147).
- (d) The panel shall be of free standing floor mounting type or pedestal mounting type as per requirement.
- (e) The panel shall be provided with double hinged doors with padlocking arrangement.
- (f) All doors, removable covers and panels shall be gasketed all around with synthetic Neoprene/EPDM gaskets generally conforming with provision of IS 11149. However, XLPE gaskets can also be used for fixing protective glass doors. Ventilating louvers, if provided shall have screens and filters. The screens shall be made of either brass or GI wire mesh.
- (g) Cable entries shall be from bottom. Suitable removable cable gland plate shall be provided on the cabinet for this purpose.
- (h) All sheet steel work shall be degreased, pickled, phosphated and then applied with two coats of zinc chromates primer and two coats of finishing synthetic enamel paint, both inside and outside. The colour of the finishing paint shall be light grey in accordance with shade no.697 of IS: 5.
- (i) Suitable heaters shall be mounted in the panel to prevent condensation. Heaters shall be controlled by thermostats so that the cubicle temperature does not exceed 30°C. On-off

switch and fuse shall be provided. Heater shall be suitable for 240V AC supply Voltage.

- (j) The test terminal blocks (TTB) to be provided shall be fully enclosed with removable covers and made of moulded, non-flammable plastic material with boxes and barriers moulded integrally. All terminals shall be clearly marked with identification numbers or letters to facilitate connection to external wiring. Terminal block shall have shorting, disconnecting and testing facilities for CT circuits.

## 28. FAULT RECORDER

- 28.1. The fault recorder shall be provided for transmission lines. The fault recorder as in-built feature of line distance relay is also acceptable provided the requirements of following clauses are met.
- 28.2. Fault recorder shall be microprocessor based and shall be used to record the graphic form of instantaneous values of voltage and current in all three phases, open delta voltage & neutral current, open or closed position of relay contacts and breakers during the system disturbances.
- 28.3. The Fault recorder shall consist of individual acquisition units, one for each feeder and an Evaluation unit which is common for the entire Substation. Whenever, more than one acquisition units are connected to an Evaluation unit, necessary hardware and software shall also be supplied for on line transfer of data from all acquisition units to Evaluation unit.
- 28.4. The acquisition unit is connected with evaluation unit being supplied as described in section sub-station automation through bus conforming to IEC 61850. In case of extension sub-station which is equipped with Sub-station Automation System based on IEC 61850, one set of evaluation software shall be supplied and loaded in existing fault recorder evaluation unit. Automatic uploading of disturbance files from acquisition unit to evaluation unit shall be done through existing station bus only conforming to IEC 61850. Necessary configuration/updation including hardware if any shall be in the scope of the contractor.
- 28.5. In case of extension of existing substation(s) which are without sub-station automation system, one set of Evaluation unit shall be supplied for each substation where ever disturbance recorders are required (**as per section-Project**) to be supplied along with necessary evaluation software as specified above. The Evaluation unit shall consist of a desktop personal computer (including at least 17" TFT colour monitor, mouse and keyboard) and **A4 size colour** printer. The desktop PC shall have **I5** processor or better and having a clock speed **2.0** GHz or better. The hard disk capacity of PC shall not be less than **1000** GB and RAM capacity shall not be less than **4** GB.
- 28.6. The evaluation unit hardware, for substations having SAS, shall be as described in section sub-station automation system.
- 28.7. Fault recorder shall have atleast 8 analogue and 16 digital channels for each feeder.

- 28.8. Acquisition units shall acquire the Disturbance data for the pre fault and post fault period and transfer them to Evaluation unit automatically to store in the hard disk. The acquisition units shall be located in the protection panels of the respective feeders.
- 28.9. The acquisition unit shall be suitable for inputs from current transformers with 1A rated secondary and capacitive voltage transformers with 63.5V (phase to neutral voltage) rated secondary. Any device required for processing of input signals in order to make the signals compatible to the Fault recorder equipment shall form an integral part of it. However, such processing of input signals shall in no way distort its waveform.
- 28.10. The equipment shall be carefully screened, shielded, earthed and protected as may be required for its safe functioning. Also, the Fault recorder shall have stable software, reliable hardware, simplicity of maintenance and immunity from the effects of the hostile environment of EHV switchyard which are prone to various interference signals typically from large switching transients.
- 28.11. Void
- 28.12. Evaluation software shall be provided for the analysis and evaluation of the recorded data made available in the PC under WINDOWS environment. The Software features shall include repositioning of analog and digital signals, selection and amplification of time and amplitude scales of each analogue and digital channel, calculation of MAX/MIN frequency, phase difference values, recording of MAX/MIN values etc. of analogue channel, group of signal to be drawn on the same axis etc, listing and numbering of all analogue and digital channels and current, voltage, frequency and phase difference values at the time of fault/tripping. Also, the software should be capable of carrying out Fourier /Harmonic analysis of the current and voltage wave forms. The Disturbance records shall also be available in COMTRADE format (IEEE standard- Common Format for Transient data Exchange for Power System)
- 28.13. The Evaluation unit shall be connected to the color printer to obtain the graphic form of disturbances whenever desired by the operator.
- 28.14. Fault recorder acquisition units shall be suitable to operate from 220V DC or 110V DC as available at sub-station. Evaluation unit along with the printer shall normally be connected to 230V, single phase AC supply. In case of failure of AC supply, Evaluation unit and printer shall be switched automatically to the station DC through Inverter of adequate capacity which shall form a part of Fault recorder system. The inverter of adequate capacity shall be provided to cater the requirement specified in section - sub-station automation and DR evaluation unit.
- 28.15. The acquisition unit shall have the following features
- (a) Facility shall exist to alarm operator in case of any internal faults in the acquisition units such as power supply fail, processor / memory fail etc and same shall be wired to annunciation system /**SAS**.

- (b) The frequency response shall be 5 Hz on lower side and 250 Hz or better on upper side.
- (c) Scan rate shall be 1000 Hz/channel or better.
- (d) Pre-fault time shall not be less than **500** milliseconds and the post fault time shall not be less than 2 seconds (adjustable). If another system fault occurs during one post-fault run time, the recorder shall also be able to record the same. **However, the total memory of acquisition unit shall not be less than 5.0 seconds.**
- (e) The open delta voltage and neutral current shall be derived either through software or externally by providing necessary auxiliary transformers.
- (f) The acquisition unit for line fault recorder shall be typically used to record **at least** the following digital channels :
  - 1 Main CB R phase open
  - 2 Main CB Y phase open
  - 3 Main CB B phase open
  - 4 Tie/TBC CB R phase open
  - 5 Tie/TBC CB Y phase open
  - 6 Tie/TBC CB B phase open
  - 7 Main-1 carrier received
  - 8 Main-1 protection operated
  - 9 Main/Tie /TBC Auto reclosed operated
  - 10 Over Voltage -Stage-1 /2 operated
  - 11 Reactor / Stub/TEE-1/2/UF protection operated
  - 12 Direct Trip received
  - 13 Main-2 carrier received
  - 14 Main- 2/ Back Up protection operated
  - 15 Bus bar protection operated
  - 16 LBB operated of main /tie/TBC circuit breaker
- (g) In case the Fault recorder is in-built part of line distance protection, above digital channels may be interfaced either externally or internally.
- (h) **The sequence of digital channels shall be as per above list and which shall be ensured by the contractor. Digital channels shall be named suitably for easy identification of signals in the fault recordings.**
- (i) Any digital signal can be programmed to act as trigger for the acquisition unit. Analog channels should have programmable threshold levels for triggers and selection for over or under levels

should be possible.

- 28.16. The **colour laser printer (A4 size)** shall be provided which shall be compatible with the desktop PC and shall use Plain paper. The print out shall contain the Feeder identity, Date and time (in hour, minute and second up to 100th of a second), identity of trigger source and Graphic form of analogue and digital signals of all the channels.
- 28.17. Each Fault recorder shall have its own time generator and the clock of the time generator shall be such that the drift is limited to  $\pm 0.5$  seconds/day, if allowed to run without synchronisation. Further, Fault recorder shall have facility to synchronise its time generator from Time Synchronisation Equipment having output of following types :
- Voltage signal : (0-5V continuously settable, with 50m Sec. minimum pulse duration)
  - Potential free contact (Minimum pulse duration of 50 m Sec.)
  - IRIG-B
  - RS232C
  - **SNTP**

The recorder shall give annunciation in case of absence of synchronising within a specified time.

- 28.18. Substations where Time Synchronisation Equipment is not available, time generator of any one of the Fault recorders can be taken as master and time generators of other Fault recorders and Event loggers in that station shall be synchronised to follow the master.

## **29. STANDALONE DISTURBANCE RECORDER ( for 765 KV Feeders only)**

A separate numerical disturbance recording function shall be provided for each 765kV lines. The following requirements shall be met:

- 29.1. The disturbance recorder shall record the analogue values form of the instantaneous values of voltage and current in all three phases, the open delta voltage and the neutral current. The open or closed position of relay contacts and circuit breakers during system disturbances shall also be recorded.
- 29.2. The disturbance recorder shall comprise distributed individual acquisition units, one for each feeder and an evaluation unit which is common for the entire substation. The acquisition units shall acquire the disturbance data for the pre-fault, fault and post-fault periods and transfer them to the evaluation unit automatically for storage on a mass storage device. The acquisition unit shall be suitable for inputs from current transformers with 1 A rated secondaries and capacitive voltage transformers with 63.5 V (phase-to-neutral voltage) rated secondaries.
- 29.3. The acquisition units shall have the following features:
- (a) A facility to alert the operator in the case of any internal faults (such as power supply fail, processor/memory fail etc.) in any of the acquisition units and this alarm shall be wired to the station

annunciation system.

- (b) The pre-fault time shall not be less than 200 milliseconds and the post fault time shall not be less than 2 seconds (adjustable). If another system disturbance occurs during a post-fault run time, the recorder shall also be able to record this subsequent disturbance. The scan rate should be selectable in the range from 1000 Hz to 5000 Hz.
- (c) The open delta voltage and neutral current shall be derived either through software or externally by providing necessary auxiliary transformers.
- (d) The acquisition unit shall be typically used to record **at least** the following digital channels:
  - 1. Main circuit-breaker R-phase open
  - 2. Main circuit-breaker Y-phase open
  - 3. Main circuit-breaker B-phase open
  - 4. Main 1 carrier received
  - 5. Main 1 protection operated
  - 6. Main/Tie auto-reclose operated
  - 7. Overvoltage stage 1/2 operated
  - 8. Reactor/Stub-1/2 protection operated
  - 9. Direct trip received
  - 10. Main 2 carrier received
  - 11. Main 2 protection operated
  - 12. Busbar protection operated
  - 13. Breaker failure protection of main/tie circuit-breaker operated
  - 14. Tie circuit-breaker R-phase open
  - 15. Tie circuit-breaker Y-phase open
  - 16. Tie circuit-breaker B-phase open

**The sequence of digital channels shall be as per above list and which shall be ensured by the contractor. Digital channels shall be named suitably for easy identification of signals in the fault recordings.**

- 29.4. The necessary hardware and software shall also be supplied for the on-line transfer of data from all acquisition units to the evaluation unit. The disturbance recording system shall be capable of handling the full complement of feeders in the substation.

**In case of extension of existing substation(s), one set of Evaluation unit shall be supplied for each substation wherever required (as per section-Project) along with necessary evaluation software as specified above.**

- 29.5. The disturbance recording equipment shall be screened, shielded, earthed and protected as may be required for its safe and proper functioning. Also, the disturbance recorder shall have stable software, reliable hardware, simplicity of maintenance and immunity from the effects of the hostile environment of a 765 kV EHV switchyard which is prone to numerous interference signals such as large switching transients.
- 29.6. The evaluation unit shall comprise all the necessary hardware and software for the proper evaluation of disturbances. The hardware would typically consist of a desktop personal computer (including a large high resolution colour monitor, mouse and keyboard) and a high-speed colour printer (**A4 size**). The desktop PC shall have **I5** processor or better and shall have a clock speed of **2.0 GHz** or better. The mass storage capacity of PC shall not be less than **1000GB** and the RAM capacity shall not be less than **4 GB**. The evaluation software required for the analysis and evaluation of the recorded data shall run on the PC under Microsoft Windows environment. The software features shall provide:
- clear and unambiguous display of all channels;
  - the ability to reposition the analog and digital traces;
  - recording of maximum/minimum values etc. of the analog channels;
  - calculation of maximum/minimum frequency and phase difference values;
  - grouping of signals for drawing on the same axis;
  - listing and identification of all analog and digital channels as well as and current, voltage, frequency and phase difference values at the time of fault/tripping;
  - the capability of carrying out Fourier/Harmonic analysis of the current and voltage waveforms; and,
  - the availability of the disturbance records in COMTRADE format
- 29.7. The evaluation unit shall be permanently connected to the printer so as to obtain the graphic display of disturbances whenever desired by the operator. The printer shall be compatible with the desktop PC and shall use plain paper. The print out shall contain the feeder identity, date and time (in hour, minute and second up to 100th of a second), identity of the trigger source and graphic representation of the analog and digital signals of all the channels.
- 29.8. The disturbance recorder acquisition units shall be suitable to operate from the station DC. The evaluation unit along and the printer shall normally be connected to the 230 V, single phase AC supply. In the case of a failure of the AC supply, the evaluation unit and printer shall be automatically switched to the station DC through an inverter of adequate capacity and which shall form part of disturbance recording system.

- 29.9. The disturbance recorder shall be capable of being triggered by the following user-specified quantities:
- (a) external start, both software and hardware
  - (b) cross triggering of groups of channels, either software or hardware or both
  - (c) binary channel (NO and NC contacts)
  - (d) over voltage and under voltage
  - (e) over current
  - (f) negative sequence voltage
  - (g) zero sequence voltage
  - (h) rate of change, voltage or current
  - (i) over frequency or under frequency
  - (j) logical or Boolean expressions, programmable
  - (k) power swing
  - (l) rate of change of active or reactive power
- 29.10. The disturbance recorder shall have its own time generator and the clock of the time generator shall be such that the drift is limited to less than  $\pm 0.5$  seconds per day, if allowed to run without synchronisation. Further, the disturbance recorder shall have the facility to synchronise its time generator from the station Time Synchronisation Equipment using IRIG-B. The recorder shall give an alarm in the case of the absence of the synchronising pulse for a pre-determined time.
30. **DISTANCE TO FAULT LOCATOR** shall
- a. be electronic or microprocessor based type
  - b. be 'On-line' type
  - c. be suitable for breaker operating time of 2 cycles
  - d. have built-in display unit
  - e. the display shall be directly in percent of line length or kilometres without requiring any further calculations
  - f. have an accuracy of 3% or better for the typical conditions defined for operating timings measurement of distance relays
  - g. The above accuracy should not be impaired under the following conditions:
    - presence of remote end infeed
    - predominant D.C. component in fault current
    - high fault arc resistance
    - severe CVT transients
  - h. shall have mutual zero sequence compensation unit if fault locator is to be used on double circuit transmission line

- i. built in feature of line distance relay is acceptable provided the requirements of above clauses are met.

**31. DISTANCE TO FAULT LOCATOR-Travelling Wave type (TWFL):**

Distance to Fault locator, based on Traveling wave detection method, shall

- a. be microprocessor based, On-line type
- b. have programmable triggering thresholds
- c. be suitable for breaker operating time of minimum 2 cycles
- d. consist of acquisition unit and one central unit
- e. provide fault location reading directly in kilo-meter without requiring any further calculations
- f. have fault location accuracy of + 150 Meter or better with a least count of atleast 50 meter for fault locator readings
- g. The above accuracy should not be affected by followings:
  - Line length
  - Presence of remote end in-feed
  - Series compensation
  - Non-uniform line (having Cable & Over head line both)
  - Mutual coupling
  - Transposition of line
  - Fault resistance
  - Severe CVT transients
- h. Acquisition units shall:
  - i. be either standalone for each line  
or  
with the capability to cater to a number of lines emanating from a substation. In case more than one lines are to be accommodated in one acquisition unit then suitable coupler unit/measuring unit shall be provided in individual line bay C&R panels and only secondary wiring shall be brought to common acquisition unit. While offering this option, bidders are advised to take care of maximum distance between Acquisition unit & line bays C&R panels. In the BPS, total no. of line bays envisaged for Travelling Wave type Fault Locators is mentioned for further assessment by the bidder for no. of Acquisition units required for total functional requirements based on equipment design.
  - ii. include all required accessories (like couplers, cables, connectors etc) to connect to the secondary wiring of the Instrument transformers (in C&R panels) for detection of traveling wave
  - iii. have built-in backlit display unit and keypad

- iv. have the facility to locally download the data in case of communication failure
  - v. have minimum 02 nos. binary input per line for line protection trip input. Binary input shall be rated for 220V DC and it shall be possible to set the de-bounce time of the binary input.
  - vi. have minimum **1GB** of storage space
  - vii. have facility to transmit the fault record to the Central unit by dialing mode, IEC60870-5-103 or IEC60870-5-104 or TCP/IP net protocol etc. Scope shall include dialup modem, if required with each Acquisition unit.
- i. include required GPS time synchronizing units for each substation (internal or external to Acquisition unit)
- j. Central data processing unit shall:
- i. Consist of a desktop personal computer (including at least 17" TFT color monitor, mouse and keyboard), colour laser jet multi-function printer (A4 size), LAN switches (as required), all special cables and other required accessories. The desktop PC shall have Intel Dual core processor or better. The hard disk capacity of PC shall not be less than 1000 GB and RAM capacity shall not be less than 4 GB.
  - ii. have all necessary hardware & software for data download from Acquisition units, storage, processing, device (acquisition unit) creation and configuration, and comprehensive viewer for manual analysis of waveform. It will also have diagnostic feature to check the healthiness of connected devices & communication link.
  - iii. calculate & report the fault location based on the traveling wave data acquired from acquisition units of both end of the line. However, Central data processing unit shall have the facility to calculate the fault location even with only one end acquisition unit data of the line.
  - iv. be able to communicate to the Master station (Control centre) through IEC60870-5-104 net protocol. Alternate Standard protocol shall also be acceptable subject to fulfilling the functional requirements.
  - v. be located at local or any remote end based on the availability of communication link. End to end communication link shall be

provided by POWERGRID. However Scope shall also include a dialup modem with central data processing unit.

- k. In cases, Central data processing unit of Travelling wave fault locator is existing at a location the Acquisition units under present scope can be integrated with the existing Central data processing unit (Make & Model of existing unit should be mentioned in section-Project) by required augmentation (configuration and up gradation of data base including supply of any additional hardware / software etc.). Alternatively, bidder may offer separate Central data processing unit & associated hardware & software as may be required under the head of augmentation of Central data processing unit.
- l. **Include required no. of panels to house the offered equipments at various substations & central location. Acquisition units can also be mounted in respective line protection panels.**
- m. **TWFL as built-in feature of Standalone fault recorder or Line Protection IED shall also be acceptable subject to meeting the functional requirement specified.**
- n. **Type test (EMI/EMC) and additional functional test for accuracy shall be submitted for TWFL for review and approval.**

## **32. TIME SYNCHRONISATION EQUIPMENT**

- 32.1. The Time synchronisation equipment shall receive the co-ordinated Universal Time (UTC) transmitted through Geo Positioning Satellite System (GPS) and synchronise equipments to the Indian Standard Time in a substation.
- 32.2. Time synchronisation equipment shall include antenna, all special cables and processing equipment etc.
- 32.3. It shall be compatible for synchronisation of Event Loggers, Disturbance recorders and SCADA at a substation through individual port or through Ethernet realised through optic fibre bus.
- 32.4. Equipment shall operate up to the ambient temperature of 50 degree centigrade and 80% humidity.
- 32.5. The synchronisation equipment shall have 2 micro-second accuracy. Equipment shall give real time corresponding to IST (taking into consideration all factors like voltage, & temperature variations, propagation & processing delays etc).
- 32.6. Equipment shall meet the requirement of IEC 60255 for storage & operation.
- 32.7. The system shall be able to track the satellites to ensure no interruption of synchronisation signal.
- 32.8. The output signal from each port shall be programmable at site for either one hour, half hour, minute or second pulse, as per requirement.
- 32.9. The equipment offered shall have six (6) output ports. Various

combinations of output ports shall be selected by the customer, during detailed engineering, from the following :

- Potential free contact (Minimum pulse duration of 50 milli Seconds.)
- IRIG-B
- RS232C
- SNTP Port
- **IEEE 1588 PTP (*Applicable only for Process bus automation station*)**

- 32.10. The equipment shall have a periodic time correction facility of one second periodicity.
- 32.11. Time synchronisation equipment shall be suitable to operate from 220V DC or 110V DC as available at Substation.
- 32.12. Equipment shall have real time digital display in hour, minute, second (24 hour mode) & have a separate time display unit to be mounted on the top of control panels/**SAS panel** having display size of approx. 100 mm height.

**33. Bay Control Unit (BCU): BCU supplied shall meet the requirements mentioned under technical specification Section- Substation automation.**

**34. INTERFACE PANEL ( If specified in BPS)**

- a) Interface panel is envisaged to minimize cabling/termination time during erection stage at site, minimize hindrance in protection panel and also ease of trouble shooting. This panel shall be installed in Switchyard panel room and one no. interface panel shall be provided for each feeder. Tie bay can be accommodated in the Interface unit of any one of the associated feeder.
- b) All control wiring from switchyard except CTs & CVTs shall be terminated in the interface panel. CTs and CVTs wiring shall be directly connected to the relay panel as per scheme requirements.
- c) All wiring from Interface panel to relay panels or other panels (Inter-panel wiring) in the switchyard panel room shall be factory fitted / terminated through Plug-in type termination arrangement. Plug-in type termination shall be heavy duty industrial grade with double locking latch or screw locking arrangement with IP65 protection.
- d) **Minimum one number spare Plug-in type connector duly terminated on each side per inter-panel wiring circuit shall be provided for future use.**

**35. MONITORING, CONTROL & PROTECTION FOR AUXILIARY TRANSFORMER**

Suitable monitoring, control (operation of associated circuit breaker & isolator) and protection for LT auxiliary transformer, connected to tertiary winding of auto transformer for the purpose of auxiliary supply shall be provided by the

contractor. Over current and open delta protection is required to be provided for the auxiliary transformer. These protection and control shall be also be acceptable as built in feature either in the bay controller to be provided for the auxiliary system or in the control & protection IEDs to be provided for autotransformer.

### 36. RELAY Test KIT

36.1. One relay test kit shall comprise of the following equipment as detailed here under

- 3 sets Relay tools kits
- 2 nos. Test plugs **for each type of TTB**
- 2 nos. Test plugs for using with modular type relays (if applicable)

### 37. CONFIGURATION OF RELAY AND PROTECTION PANELS

The following is the general criteria for the selection of the equipments to be provided in each type of panel. However, contractor can optimise the requirement of panels by suitably clubbing the feeder protection and CB relay panels. It may be noted that Main-I and Main-II protections for line can not be provided in single panel. Similarly, Group-I & Group-II protections for transformer can not be provided in single panel.

**I) LINE PROTECTION PANEL:** The Line Protection panel for transmission lines shall consist of following protection features/schemes

Sl. No.	Description	765kV	400kV	220kV	132kV
1.	Main-1 protection scheme	1 Set	1 Set	1 Set	1 Set
2.	Main-2 protection scheme	1 Set	1 Set	1 Set	NIL*
3.	Over Voltage Protection Scheme	1 Set	1 Set	NIL	NIL
4.	Fault Recorder	1 Set	1 Set	1 Set	NIL
5.	Standalone Disturbance Recorder	1 Set	NIL	NIL	NIL
6.	Distance to fault Locator	1 Set	1 Set	1 Set	1 Set
7.	<b>Cut out for mounting of Distance to fault Locator (TWFL)</b>	<b>1 Set#</b>	<b>1 Set#</b>	NIL	NIL
8.	3 Phase Trip Relays	2 Nos.	2 Nos.	2 Nos.	2 Nos.
9.	Flag relays, carrier receive relays, aux. Relays, timers etc as per scheme requirements	As required	As required	As required	As required
10.	Under Voltage protection relay for isolator/earth switch <b>Interlock</b>	2 Nos	2 Nos	2 Nos	2 Nos

Sl. No.	Description	765kV	400kV	220kV	132kV
11..	Cut-out and wiring with TTB for <b>Employer</b> supplied energy meter	1 Set	1 Set	1 Set	1 Set
12.	Directional Back up Over current and E/F protection scheme	NIL	NIL	NIL	1 Set
Note- 1)	*Back up –directional O/c & E/F protection is specified for 132kV system in place of Main-II				
Note- 2)	In a substation where 765kV, 400kV and 220 KV lines are under the scope of the contract, bidder is required to give identical Main-1 and Main-2 distance protection schemes for all voltage levels.				
Note- 3)	Cut out & mounting arrangement provided for POWERGRID supplied energy meter shall be suitable for mounting of energy meter unit of 4” thickness				
Note-IV	<b># Cut out for mounting of Distance to Fault locator (Travelling wave type) shall be provided.</b>				

**II) TRANSFORMER PROTECTION PANEL:** The protection panel for Auto transformer/Transformer shall consists of the following features/schemes:

Sl. No.	Description	HV side	MV/LV side
1.	Transformer Differential Protection scheme	1 Nos.	Nil
2.	Restricted Earth fault protection scheme	1 no.	1 no@
	<i>@ Not applicable for auto-transformer</i>		
3.	Directional back up O/C and E/F relay with non-directional high set feature	1 set	1 set
4.	Over Fluxing Protection scheme	1 no.	1 no.\$
	<i>\$ Applicable only for 400/220kV Transformer &amp; 765/400kV Transformer</i>		

5.	Overload protection scheme	1 nos.	NIL
6.	Three phase trip relays	2 nos.	2 nos.
7.	CVT selection relays as per scheme requirement	Lot	Lot
8.	Cut-out and wiring with TTB for POWERGRID supplied energy meter	1 set	1 set
9.	Transformer Neutral Current relay for 1-Phase transformer bank	1 Set	
10.	<b>Tertiary side O/C and Open delta Voltage protection</b>	<b>1 Set</b>	
11.	Flag Relays/Aux. Relays for wiring Transformer auxiliary protection contacts such as Buchholz, Oil Temperature, Winding Temperature, PRV, SPRD, OLTC Buchholz etc. as per scheme requirements	As required	
Note- 1)	<b>Tertiary side protections, over fluxing protection and overload protection can be clubbed in other transformer protection relay, however, over fluxing protection of HV and MV/LV side cannot be clubbed together. Further, tertiary side protection, if provided in auxiliary BCU, shall be excluded from this panel. This protection shall be applicable only for the transformer whose tertiary side is connected to LT transformer for station auxiliary supply.</b>		
Note- 2)	Cut out & mounting arrangement provided for POWERGRID supplied energy meter shall be suitable for mounting of energy meter unit of 4" thickness		

**III) REACTOR PROTECTION PANEL:** The protection panel for Reactor shall consist of the following features/schemes:

Sl. No.	Description	Qty.
1.	Reactor Differential Protection scheme	1 no.
2.	Restricted Earth fault Protection scheme	1 no.
3.	Reactor back up impedance protection scheme	1 set
4.	Three phase trip relays	2 nos.
5.	CVT selection relay as per scheme requirement	Lot
6.	Flag Relays/Aux. Relays for wiring Reactor auxiliary protection contacts such as Buchholz, Oil Temperature, Winding Temperature, PRV, SPRD etc. as per scheme requirements	As required

**IV) BREAKER RELAY PANEL:** The breaker relay panel shall consist of the following:

Sl. No.	Description	With A/R	Without A/R
1.	Breaker failure Protection Scheme *	1 No.	1 No.
2.	DC supply Supervision relay	2 Nos.	2 Nos.
3.	Trip Circuit supervision relays#	6 Nos.	6 Nos.
4.	Auto-reclose scheme (if standalone)	1 Nos.	NIL
5.	Flag relays, aux relays, timers, trip relays as per scheme requirements	As required	As required
Note- 1)	# Trip supervision relays shall be 2 or 6 numbers as per no. of trip coils for each 132KV Circuit breaker		
Note- 2)	Equipment/relays to be provided under CB Relay Panel may be accommodated in the Protection Panels to be provided for Transmission Line/Transformer/Reactor as applicable.		
Note- 3)	* In case of bay extension in existing half diameter, breaker failure relay for main CB / Tie CB shall be supplied only if BFR built-in Bus Bar protection bay unit is not available or Tie CB standalone BFR relay is not available in the existing protection scheme.		

**V) CONTROL PANEL:** Various types of control panels shall consist of the following:

a.	Ammeter	3 set	for each Line, BC, TBC Bus section, Bus Reactor and Transformer
b.	Ammeter with Selector switch	1 set	for each line reactor
c.	Wattmeter with transducer	1 set	for each line, transformer
d.	Varmeter with transducer	1 set	for each line, transformer, Bus reactor
e.	Varmeter with transducer	1 set	for each Line Reactor
f.	CB Control switch	1 no.	for each Circuit breaker
g.	Isolator Control switch	1 no.	for each isolator
h.	Semaphore	1 no.	for each earth switch
i.	Red indicating lamp	1 no.	for each Circuit breaker
j.	Red indicating lamp	1 no.	for each isolator
k.	Green indicating lamp	1 no.	for each Circuit breaker
l.	Green indicating lamp	1 no.	for each isolator

m.	White indicating lamp (DC healthy lamp)	2 nos.	for each feeder
n.	Annunciation windows with associated annunciation relays	18 nos.	for each feeder
o.	Push button for alarm Accept/reset/lamp test	3 nos.	for each control panel
p.	Synchronising Socket	1 no.	for each Circuit Breaker, if required
q.	Synchronising selector Switch	1 no.	for each Circuit Breaker switch, if required
r.	Protection Transfer Switch	1 no.	for each breaker in case of DMT /DM with bypass isolator / SMT schemes (Except TBC and BC breaker)
s.	Mimic to represent SLD	Lot	in all control panels
t.	Voltmeter with selector Switch	1 no.	for each line, transformer, bus reactor
u.	Cut out, mounting and wiring for RWTI and selector switch	Lot	for transformers/reactors

**Notes:**

- 1 For transformer feeders, all equipments of control panel shall be provided separately for HV and MV sides.
2. In case of incomplete diameter (D and I type layouts), control panel shall be equipped fully as if the diameter is complete, unless otherwise specified. Annunciation relays shall also be provided for the same and if required, necessary panel shall be supplied to accommodate the same.
3. The above list of equipments mentioned for control panel is generally applicable unless it is defined elsewhere and in case of bay extension in existing substations, necessary equipments for matching the existing control panel shall be supplied.
4. Each line /HV side of transformer/MV/LV side of transformer /Bus reactor /TBC /Tie / BC/ Bus Section shall be considered as one feeder for above purpose.

**VI) CONTROL PANEL WITH BAY CONTROL UNIT (BCU):** Various types of control panels shall consist of the following:

a.	Bay Control Unit (BCU)	1 set	for each Circuit Breaker
----	------------------------	-------	--------------------------

b.	Ethernet switch complying IEC61850	1 no.	for each control panel
c.	Selector switch for Local/Remote bay control	1 no.	for each Circuit Breaker
d.	Ammeter with transducer & Selector switch	1 set	for each Line, BC, TBC, Bus section, Bus reactor, Transformer and line reactor
e.	CB Control switch	1 no.	for each Circuit breaker
f.	Red indicating lamp	1 no.	for each Circuit breaker
g.	Green indicating lamp	1 no.	for each Circuit breaker
h.	White indicating lamp (DC healthy lamp)	2 nos	for each feeder
i.	Common Annunciation lamp	1 no.	for each control panel
j.	Common hooter	1 no.	for each control panel
k.	Synchronising Socket	1 no.	for each Circuit Breaker if required
l.	Synchronising selector Switch	1 no.	for each Circuit Breaker switch if required
m.	Protection Transfer Switch	1 no.	for each breaker in case of DMT /DM with bypass isolator/ SMT schemes (Except TBC and BC breaker)
n.	Mimic to represent SLD	Lot	in all control panels
o.	Voltmeter with selector Switch	1 no.	for each line, transformer, bus reactor

**Notes:**

1. For transformer feeders, all equipments of control panel shall be provided separately for HV and MV sides.
2. In case of incomplete diameter (D and I type layouts), control panel shall be equipped fully as if the diameter is complete, unless otherwise specified. Annunciation relays shall also be provided for the same and if required, necessary panel shall be supplied to accommodate the same.
3. The above list of equipments mentioned for control panel is generally applicable unless it is defined elsewhere and in case of bay extension in existing substations, necessary equipments for matching the existing control panel, if applicable, shall be supplied.
4. Each line /HV side of transformer/MV/LV side of transformer /Bus reactor /TBC /BC/ Bus Section shall be considered as one feeder for above purpose.

6. **Control panel with BCU can be combined in the CB relay panels being supplied under present scope.**
7. The Bay Control unit and the numerical relays supplied under present scope shall be connected to the Ethernet switch. The ethernet switch shall comply with IEC 61850-3 requirements. It shall have sufficient number of ports to accommodate all the IEDs of the new bays and at least 6 spare ports for integrating the numerical Relays/BCUs with NTAMC system i.e. redundant Gateways/RTU and redundant SDC and two spare ports. The IP addressing scheme for the devices shall be provided by POWERGRID.
9. Selector switch for Local/Remote bay control shall be provided to transfer the control between the BCU and the Control panel. The control shall be available to either the BCU or from the Control panel however data monitoring shall be available at both the devices
10. The Bay control unit shall be flush mounted in the panel with their mimic displays accessible from the front of the panel. The Bay control unit mimic shall dynamically represent the current value of the measurements, state of the devices and control of devices. The Bay control unit shall provide telemetry and tele-control for remote operation from control centres (NTAMC). The Bay control unit shall acquire all the analog measurements, Status of Circuit breakers, Isolators and Earth switches, status of alarms, and provide Control of devices (Circuit breaker/Isolators/Reset of Relays/position selection for Auto reclose etc). The Bay control unit shall also provide synchronization check facility for the circuit breakers suitable for the bus bar scheme.
11. For Protection transfer switch function in Transfer bus schemes- The High Speed Bi-stable relays for protection transfer from 'Normal' to 'Transfer' and vice versa, whose position can be controlled locally as well as from remote via BCU shall be provided. The position once selected should not change in case of Power cycling.
12. In case the control panel is being provided in switchyard panel room, its common alarm signal shall also initiate an alarm facia in any of the existing control panel in control room building.

### **38. ERECTION AND MAINTENANCE TOOL EQUIPMENTS**

All special testing equipment required for the installation and maintenance of the apparatus, instruments devices shall be furnished in relevant schedule.

### **39. TROPICALISATION**

Control room/ **Panel room** will be normally air-cooled/air- conditioned. All equipments shall however be suitable for installation in a tropical monsoon area having hot, humid climate and dry and dusty seasons with ambient conditions specified in the specification. All control wiring, equipment and accessories shall be protected against fungus growth, condensation, vermin and other harmful effects due to tropical environment.

## 40. TYPE TESTS

40.1. The reports for following type tests shall be submitted during detailed engineering for the Protective relays, Fault Recorder, Fault locator and Disturbance recorder:

- a) Insulation tests as per IEC 60255-5
- b) DC Voltage dips and interruptions/Variation as per IEC 61000-4-29 **or IEC 60255-11**
- c) High frequency (1MHz burst) disturbance test **as per IEC 60255-22-1** (Not applicable for electromechanical relays)
- d) Electrostatic discharges as per IEC 61000-4-2, level; 4 **or IEC 60255-22-2 with severity Class III** (not applicable for Electromechanical relays)
- e) Fast transient test as per IEC 61000, Level IV **or IEC 60255-22-4 with severity level IV** (Not applicable for electromechanical relays)
- f) Relay characteristics, performance and accuracy test as per IEC 60255
  - Steady state Characteristics and operating time
  - Dynamic Characteristics and operating time for distance protection relays and current differential protection relays
  - Conformance test as per IEC 61850-10.

For Fault recorder, Disturbance recorder; only performance tests are intended under this item.

- g) Tests for thermal requirements as per IEC 60255-6
- h) Tests for rated burden as per IEC 60255-6
- i) Contact performance test as per IEC 60255-0-20 **or IEC61810-2** (not applicable for Distance to fault locator and Disturbance recorder)
- j) **Tests for mechanical requirements ( Vibration, shock & bumps and seismic) as per IEC 60255-21-1, 2 & 3 with severity class-I**
- k) **Test for Radiated Electromagnetic Field Disturbance as per IEC 60255-22-3 with severity class III** (not applicable for electromechanical relays)

In case there is a change either in version or in model (Except firmware) of the relay, the contractor shall submit the type test reports for the offered revision/model.

40.2. Steady state & Dynamic characteristics test reports on the distance protection relays, as type test, shall be based on test programme specified in Appendix A on simulator/network analyser/PTL. Alternatively, the files generated using Electromagnetic transient Programme (EMTP) can also be used for carrying out the above tests. Single source dynamic tests on transformer differential relay shall be/ should have been conducted based on general guidelines specified in CIGRE committee 34 report on

Evaluation of characteristics and performance of Power system protection relays and protective systems.

41. Other general requirement for Protection IEDs:
  - a. Relay setting template (in editable document format) shall be provided by the contractor for each typical protection IEDs for relay setting purpose.
  - b. POWERGRID has standardised binary input/output details, indication details, DR signals texts etc. of protection IEDs & Protection Panels CT/VT circuit termination detail and same shall be provided to contractor during detail engineering for preparation of schematics. Panel nomenclature, terminal blocks identification, as applicable, shall be according to typical detail given at APPENDIX-B.
42. Requirement for GIS substations:

GIS Gas zone trip signals, if provided, for each gas tight compartments (gas zone) in the GIS LCC shall be integrated in the protection schematics to provide electrical isolation of faulty Gas zone by tripping/inter-tripping its adjacent circuit breakers. The scheme shall be implemented through protection IEDs and auxiliary relay as required.

## Test programme for distance relays

### General Comments:

1. These test cases are evolved from the report of working group 04 of study committee 34 (Protection) on evaluation of characteristics and performance of power system protection relays and protective systems. For any further guidelines required for carrying out the tests, reference may be made to the above document.
2. The test shall be carried out using network configuration and system parameters as shown in the figure-1
3. All denotations regarding fault location, breakers etc are referred in figure –1
4. The fault inception angles are referred to R- N voltage for all types of faults
5. The fault inception angle is zero degree unless otherwise specified
6. Where not stated specifically, the fault resistance (Rf) shall be zero or minimum as possible in simulator
7. Single pole circuit breakers are to be used
8. The power flow in double source test is 500 MW

### System parameters

System voltage =400KV

CTR= 1000/1

PTR = 400000/110 (with CVT, the parameters of CVT model are shown in figure –2)

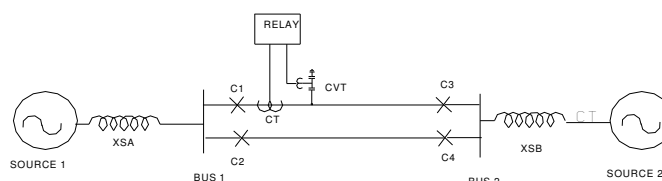

FIGURE 1

### Line parameters/km

Positive Sequence Resistance, (r1)	= 0. 02897 $\Omega$
Positive Sequence Reactance (x1)	= 0.3072 $\Omega$
Zero Sequence Resistance (r0)	= 0.2597 $\Omega$
Zero Sequence Reactance (x1)	= 1.0223 $\Omega$
Zero Sequence Mutual Resistance (rm)	= 0.2281 $\Omega$
Zero Sequence Mutual Reactance (xm)	= 0.6221 $\Omega$
Zero Sequence susceptance (bo)	= 2.347 $\mu$ mho
Positive Sequence susceptance (b1)	=3.630 $\mu$ mho

Type of line	Short		Long
Secondary line impedance	2 $\Omega$		20 $\Omega^*$
Length of line in Kms	23.57		235.7
SIR	4	15	4
Source impedance (pry) (at a time constant of 50 ms)	29.09 $\Omega$ (5500 MVA)	109.09 $\Omega$ (1467 MVA)	290.9 $\Omega$ (550 MVA)

\* Alternatively, the tests can be done with 10  $\Omega$  secondary impedance and source impedance may accordingly be modified

### CVT Model

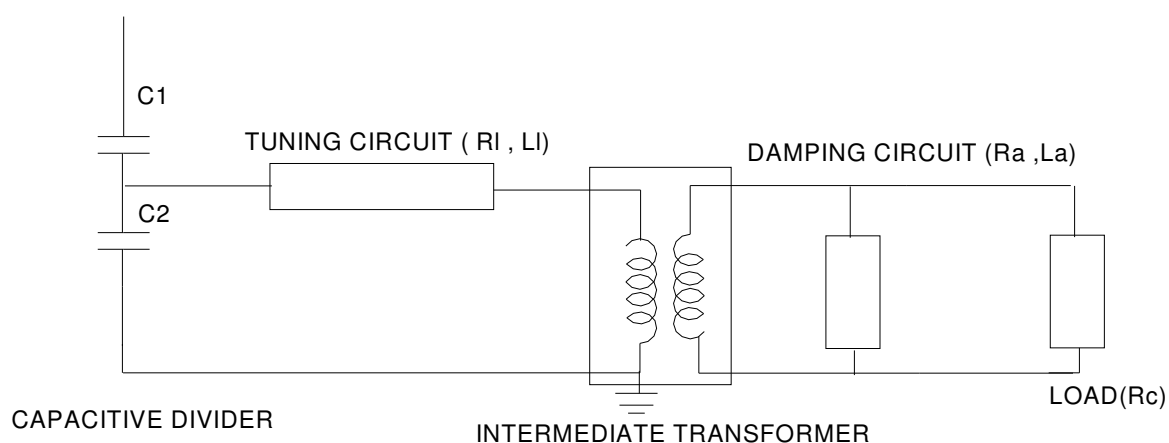

Figure-2

XC1	1.455 $\mu$ mho
XC2	27.646 $\mu$ mho
RI	320 $\Omega$
XLI	34243 $\Omega$
Ra	4.200 $\Omega$
Xla	197.92 $\Omega$
Rc	14.00 $\Omega$
Transformation ratio of Intermediate transformer	181.8

## Details of fault cases to be done

Sl no	Description	Single source with short line (2 Ω)		Single source long line (20 Ω)	Double source with short double line (2 Ω)	Double source with long single line (20 Ω)
		CLOSE C1, OPEN C2,C3,C4		CLOSE C1, OPEN C2,C3,C4	CLOSE C1, C2,C3,C4	CLOSE C1,C3 OPEN C2,C4
		SIR=4	SIR=15	SIR =4	SIR = 4	SIR=4
1	Dynamic accuracy for zone 1	Tests to be done at 2 locations ( 84 % and 76 % of line length ) X 4 faults (RN , YB, YBN, RYB) X 2 fault inception angle (0°, 90°)= 16 cases	Tests to be done at 2 locations ( 84 % and 76 % of line length ) X 4 faults (RN , YB, YBN, RYB) X 2 fault inception angle (0°,90°)= 16 cases	Tests to be done at 2 locations ( 84 % and 76 % of line length ) X 4 faults (RN , YB, YBN, RYB) X 2 fault inception angle (0°,90°)= 16 cases		Tests to be done at 2 locations (84% and 76% of line length) X 4 faults (RN , YB, YBN, RYB) X 2 fault inception angle (0°, 90°)= 16 cases
2	Operating time for zone 1 at SIR =4	Tests to be done at 3 locations (0% , 40% and 64% of line length ) X 4 faults (RN, YB, YBN, RYB) X 4 fault inception angle (0°, 30°,60° and 90°) = 48 cases	Tests to be done at 3 locations (0 % , 40 % and 64 % of line length ) X 4 faults (RN , YB, YBN, RYB) X 4 fault inception angle (0°,30°,60° and 90°)= 48 cases	Tests to be done at 3 locations ( 0 % , 40 % and 64 % of line length ) X 4 faults (RN , YB, YBN, RYB) X 4 fault inception angle (0°, 30°,60° and 90°)= 48 cases	Tests to be done at 1 location (40 % of line length) X 4 faults (RN, YB, YBN, RYB) X 4 fault inception angle (0°,30°,60° and 90°)= 16 cases	Tests to be done at 1 location (40 % of line length ) X 4 faults (RN, YB, YBN, RYB) X 4 fault inception angle (0°,30°,60° and 90°)= 16cases
3	Operating time for zone II and Zone III	Tests to be done at 1 location ( 100 % of line length ) X 1 faults (RN, YB, YBN, RYB) X 2 zones (II and III) = 2 cases	Tests to be done at 1 location (100 % of line length) X 1 faults (RN , YB, YBN, RYB) X 2 zones (II and III) = 2 cases	Tests to be done at 1 location (100 % of line length ) X 1 faults (RN , YB, YBN, RYB) X 2 Zones (II and III) = 2 cases		

S n o	Description	Single source with short line (2 Ω)		Single source long line (20 Ω)	Double source with short double line (2 Ω)	Double source with long single line (20 Ω)
4	Switch on to fault feature			Tests to be done at 2 location ( 0 % and 32 %) X 1 faults (RYB) Any fault inception angle = 2 cases		
5	Operation during current reversal				Tests to be done at 2 location (0 % and 80 % of line length ) X 1 faults ( RN) X 1 fault inception angle (0 degrees) = 2 cases	
		CLOSE C1, OPEN C2,C3,C4		CLOSE C1, OPEN C2,C3,C4	CLOSE C1, C2,C3,C4	CLOSE C1,C3 OPEN C2,C4
		SIR=4	SIR=15	SIR =4	SIR = 4	SIR=4
6	Operation at simultaneou s faults				Tests to be done at 2 location (8 % and 64 % of line length ) X 2 faults ( RN in circuit 1 to BN in circuit 2 and RN in circuit 1 to RYN in circuit 2 in 10 ms) X 1 fault inception angle ( 0 °) = 4 cases (*1)	
7	Directional sensitivity					Tests to be done at 1 location (0% reverse) X 6 faults ( RN

Si no	Description	Single source with short line (2 Ω)		Single source long line (20 Ω)	Double source with short double line (2 Ω)	Double source with long single line (20 Ω)
						,YB, YBN , RYB,RN with Rf=13.75 ohm(sec) and RYN with Rf= 13.75 Ohm (sec) X 2 fault inception angle (0°,90° ) = 12cases
8	Limit for fault resistance					Tests to be done at 2 location ( 0% and 68 % of line length) X 1 fault ( RN with Rf=13.75 ohm(sec) X 2 fault inception angle (0°,90°) = 4 cases
9	Operation at evolving faults					Tests to be done at 2 location (32 % and 0% of line length) X 2 faults (RN to RYN) x in 2 timings (10 ms and 30 ms) X 2 load direction (from A to B and from B to A) = 16 cases
9	Fault locator function , in case the same is offered as built in feature	Measure fault location for all cases under 1 and 2	Measure fault location for all cases under 1 and 2	Measure fault location for all cases under 1 and 2	Measure fault location for all cases under 2 and 6	Measure fault location for all cases under 2, 7 and 9

## Terminal Block (TB) Nomenclature for Relay & interface panels

Circuit type	TB for external connections	TB for Interpanel connections
CT	X:CT	XI:CT
PT	X:VT	XI:VT
AC Auxiliary	X:AC	XI:AC
DC Auxiliary	X:DC	XI:DC
Trip Circuit 1	X:TC1	XI:TC1
Trip Circuit 2	X:TC2	XI:TC2
LBB & BB	X:LBB	XI:LBB
CB	X:CB/X:CBT	XI:X
ISOLATOR	X:ISA/ISB/ISL/ISR	XI:X
EARTH SWITCH	X:ES	XI:X
PROTECTION COUPLER	X:PC	XI:PC
ENERGY METER	X:EM	---
Reactor	X:SR	XI:SR
Transformer	X:AT	XI:AT
Others Control & status signals	X:X	XI:X

### Feeder relay Panels designation:

Typical Bay / Busbar	Panel Ref.
765kV Bay no. 1 (701)	7R1A, 7R1B and so on
400kV Bay no. 1 (401)	4R1A, 4R1B and so on
220kV Bay no. 1 (201)	2R1A, 2R1B and so on
132kV Bay no. 1 (101)	1R1A, 1R1B and so on
Bus 765kV	7BB1, 7BB2 and so on
Bus 400kV	4BB1, 4BB2 and so on
Bus220kV	2BB1, 2BB2 and so on
Bus132kV	1BB1, 1BB2 and so on